

E-TENDER
FOR
FABRICATION AND SUPPLY OF ALUMINIUM
ANODIZED EXTRUDED DISPLAY SECTIONS
(SIMA) –
SELF COLOUR
STRICTLY AS PER DRAWING AND
SPECIFICATIONS
AT
NATIONAL SCIENCE CENTRE, DELHI



Ministry of Culture
Government of India

NATIONAL SCIENCE CENTRE

(A UNIT OF NATIONAL COUNCIL OF SCIENCE MUSEUMS)

NEAR GATE NO.4, PRAGATI MAIDAN
BHAIRON ROAD, NEW DELHI – 110 001

NATIONAL SCIENCE CENTRE
(A Unit of National Council of Science Museums)
Bhairon Road, Near Gate No. 4, Pragati Maidan,
New Delhi – 110001

NOTICE INVITING E-TENDER

TENDER No. NSCD/18011/E-Tender -30/ 2024-25

On-line digitally signed open e-tenders are invited from reputed manufacturers/authorized dealers for **Fabrication and Supply of Aluminium Anodized Extruded Display Sections (SIMA) – Self Colour strictly** as per the Centre drawings and specifications. Vendors having proven experience and capability of executing the order at a time may download the Tender Papers from Central Public Procurement Portal (CPPP), <http://eprocure.gov.in/eprocure/app> or from Centre's website www.nscdelhi.org or www.nscd.gov.in as per the following schedule :-

Bid Document Published Date	03/02/2025 (17:00 PM)
Bid Document Download Start Date	03/02/2025 (17:15 PM)
Bid Clarification Start Date	03/02/2025 (17:30 PM)
Bid Submission Start Date	03/02/2025 (17:45 PM)
Bid Clarification End Date	07/02/2025 (16:00 PM)
Bid Submission End Date	24/02/2025 (14:30 PM)
Techno-Commercial Bid Opening Date	25/02/2025 (15:00 PM)
Financial Bid Opening date	To be Communicated Later On
Estimated Cost of Work	₹ 20.06 Lakh (Inclusive of all Taxes)
Earnest Money Deposit	₹ 50,150/-
Period of Completion of Work	TO BE CONFIRMED

The on-line bid should be uploaded by the due date and time as per the above schedule. Online Technical (Techno-Commercial) Bid will be opened at the first instance in this office **at 03:00 PM on 25/02/2025** for technical evaluation as well as selection of techno-commercially acceptable offers and at the second stage, the Financial Bids of only the selected and techno-commercially acceptable offers will be opened at a later date to be notified in the portal later subject to completion of Technical Evaluation of the offers. Decision of the Centre regarding selection of eligible and qualified vendors/firms and or equipment in particular for opening the Financial Bid shall be final and binding on the bidders.

NSC, Delhi reserves the right to accept or reject any or all tenders in full or part without assigning any reason whatsoever. NSCD shall also not be bound to accept merely the lowest tender but the technical suitability, capability and superiority of the materials as well as after sales service including infrastructure to render such service etc. shall be of prime consideration for selection of the materials.

CHECK LIST

Check list of Tender No. **NSCD/18011/E-Tender-30/2024-25** for “**Fabrication and Supply of Aluminium Anodized Extruded Display Sections (SIMA) - Self Colour strictly as per drawing and specifications at National Science Centre, Delhi.**”

S. No.	Description	Yes	No
01.	Whether E-tender uploaded on Central Public Procurement Portal of Govt. of India in two parts (i.e. Technical & Commercial) separately.		
02	Whether tender documents are carefully studied & understood.		
03	Whether tender documents duly signed and stamped on all pages is scanned and uploaded as Part – I of the tender in Central Public Procurement Portal.		
04	Whether Earnest Money of ₹ 50,150/- submitted by Online / Demand Draft No.dated..... and Scanned copy of DD uploaded as Part – I of the tender. Please note that the Original DD should be couriered /hand delivered to National Science Centre, Delhi (NSCD)/Online payment details shall be sent to NSCD before the opening time of technical bid.		
05	Whether declaration regarding Non-relation, duly signed and stamped, and scanned copy of the same uploaded as Part – I of the Tender in Central Public Procurement Portal. Annexure C (Declaration-I)		
06	Whether declaration certifying that there is no extra conditions quoted in the Offer Form duly signed and stamped, and scanned copy of the same uploaded as Part – I of the Tender in Central Public Procurement Portal. Annexure C (Declaration-II)		
07	Did you visit the actual site for execution of the work/supply before submitting the Tender.		
08	Authorization Letter issued from OEM enclosed with the Technical Bid.		
09	FOR INR Bids: Whether bidder is a registered Micro or Small Enterprises (MSE) and “Manufacturer” for the item quoted – YES/NO. If yes, copy to be enclosed (non-submission of copy as a Manufacturer will not be entitled for benefits claimed as per government policy).		
10	Indicate the ‘Country of Origin’ of the goods		
11	Whether the goods offered are from a country which shares a land border with India-Yes/No		

12	<p>Whether the following Mandatory Declaration Forms (attached with Bid) have been downloaded, signed & uploaded in the Bid.</p> <p>(Make in India w.r.t. Declaration form for local content of the offered product as per Government Public Procurement Order No. P-45021/2/2017-PP(BE-II) dated 04/06/2020).</p> <p style="text-align: right;">Annexure-H</p>		
13	<p>(Declaration form w.r.t. restrictions on procurement from Bidders from a country or countries, or a class of countries under Rule 144 (xi) of the General Financial Rules 2017).</p> <p style="text-align: right;">Annexure-I</p>		
14	<p>Drawing and Detailed Specifications of the tendered item have been downloaded, signed & uploaded in the Bid.</p> <p style="text-align: right;">Annexure-F</p>		
15	<p>EMD Furnished – YES /*NO (For tenders having EMD condition mentioned) * EMD exemption ONLY as listed under General Terms & Conditions of Tender.</p>		

Date:
Place:

Signature of the Tenderer
Official Seal

GENERAL INFORMATION AND INSTRUCTIONS

1. The instruction given herein will be strictly binding on the tenderers and deviation, if any will make the tender or tenders liable to be considered invalid. Tenders incorporating additional conditions by the tenderer are liable for rejection.
2. Bids shall be submitted online only at CPPP website: <https://eprocure.gov.in/eprocure/app> Manual bids shall not be accepted.
3. The instruction given in **ANNEXURE-A (Instruction for Online Bid Submission)** should be strictly followed during submission of the bid.
4. Bid documents may be scanned with 100 dpi with black and white option which helps in reducing size of the scanned document.
5. Bid should be submitted along with the Earnest Money of ₹50,150/- (Rupees Fifty Thousand One Hundred Fifty only) through NEFT/RTGS in the account of National Science Centre as per Annexure-F or by way of crossed Demand Draft / Pay Order on any nationalized bank of India payable in favour of "NATIONAL SCIENCE CENTRE, Payable at DELHI". Earnest Money deposit in the form of Bank Guarantee /Bond or any other instrument shall not be accepted and shall be rejected straightway. Earnest Money deposits in respect of such offers which are not accepted will be returned to the bidders within 30 working days from the date on which the final decision is taken about the source from which the items under tender are to be procured or within 2 (two) months from the date of the opening of the tenders, whichever is earlier. No interest will be paid on the Earnest Money deposited with the Council. Earnest Money deposit in respect of the successful bidders will be retained with the NSCD until entire execution of the order as per terms of the tender. If the successful bidder fails to execute the order strictly as per the NSCD's specification in full or part within the stipulated delivery period of the purchase order, the Earnest Money deposit retained with the NSCD shall be forfeited forthwith after cancellation of the concerned order.
6. **Validity of Bids:** The Bids should remain valid for 180 days from the date of bid opening.
7. **Rejection of Bids:** Canvassing by the bidder in any form, unsolicited letter and post-tender correction may invoke summary rejection. Conditional tenders will be rejected. Non-compliance of applicable General Information and Instruction will disqualify the bid.
8. The tenderers should have Digital Signature Certificate (DSC) for filling up the Bids. The person signing the tender documents should be authorized for submitting the on line e-tender.
9. The Financial Bid (BOQ) shall be filled in and signed by the authorized signatory online as per Proforma **ANNEXURE-E** available at Central Public Procurement Portal e-tender system website <http://eprocure.gov.in/eprocure/app>. Off line financial bid shall not be accepted.
10. Tender must be uploaded in two separate covers marked Cover-1 and Cover-2. The contents of Cover-1 and Cover-2 will be as follows:-

FOR COVER-1

- (i) Scanned copy of General Terms & Conditions as detailed in **ANNEXURE-B** duly signed by the authorised signatory with official stamp as a token of acceptance of the Terms & Conditions.

- (ii) Copy of the current and valid Trade License and Dealership Certificate, as applicable, duly signed by the authorised signatory with official stamp.
- (iii) Scanned Copy of the current and valid GST Registration Certificate indicating GST number & PAN duly signed by the authorized signatory with official stamp.
- (iv) The ‘Declaration-I & II’ of the bidder (as detailed in **ANNEXURE-C**) duly signed by the authorized signatory with official stamp.
- (v) Technical (Techno-Commercial) bid as per **ANNEXURE-D** format duly filled in and signed by the authorised signatory with official stamp.
- (vi) Scanned copies of the Centre ‘Drawings & Technical Specification’ (as detailed in **ANNEXURE-F**) duly signed by the authorized signatory with official stamp as a token of acceptance for supply of materials in accordance to the same.
- (vii) Scanned copy of credentials of past experience in such business.
- (viii) Bid Security Declaration form (as per **ANNEXURE-G**) duly filled and signed and sealed by the authority of the Firm.
- (ix) Scanned copy of Demand Draft for ₹50,150/- as Earnest Money Deposit or scanned copy of MSME/NSIC/UDHYAM certificate for exemption of EMD.

FOR COVER-2

- (x) The Financial Bid (**as per ANNEXURE-E format**) i.e. Schedule of Price Bid in the form of attached BOQ Proforma shall be duly filled in, digitally signed and uploaded online by the bidder.
- (xi) The Cover-1, i.e. Technical (Techno-Commercial) Bid shall be opened by the Centre at the first instance and evaluated by the competent authority of the Centre. At the second stage, the Cover-2 containing Financial Bid of only techno-commercially acceptable offers shall be opened for further evaluation and ranking before awarding the contract.
- (xii) The authorities of National Science Centre, Delhi, who does not bind themselves to accept the lowest tender, reserves the right to reject or accept any or all tenders wholly or partially without assigning and reason whatsoever.

NATIONAL SCIENCE CENTRE
(A Unit of National Council of Science Museums)
Bhairon Road, Near Gate No. 4, Pragati Maidan,
New Delhi – 110001

NOTICE INVITING E-TENDER

TENDER No. NSCD/18011/E-Tender -30/ 2024-25

INSTRUCTIONS FOR ONLINE BID SUBMISSION

The bidders are required to submit soft copies of their bids electronically on the CPP Portal, using valid Digital Signature Certificates. The instructions given below are meant to assist the bidders in registering on the CPP Portal, prepare their bids in accordance with the requirements and submitting their bids online on the CPP Portal. More information useful for submitting online bids on the CPP Portal may be obtained at <https://eprocure.gov.in/eprocure/app>

REGISTRATION

1. Bidders are required to enroll on the e-Procurement module of the Central Public Procurement Portal (URL: <https://eprocure.gov.in/eprocure/app>) by clicking on the link “**Online bidder Enrollment**” on the CPP Portal which is free of charge.
2. As part of the enrolment process, the bidders will be required to choose a unique username and assign a password for their accounts.
3. Bidders are advised to register their valid email address and mobile numbers as part of the registration process. These would be used for any communication from the CPP Portal.
4. Upon enrolment, the bidders will be required to register their valid Digital Signature Certificate (Class II or Class III Certificates with signing key usage) issued by any Certifying Authority recognized by CCA India (e.g. Sify / nCode / eMudhra etc.), with their profile.
5. Only one valid DSC should be registered by a bidder. Please note that the bidders are responsible to ensure that they do not lend their DSC’s to others which may lead to misuse.
6. Bidder then logs in to the site through the secured log-in by entering their user ID / password and the password of the DSC / e-Token.

SEARCHING FOR TENDER DOCUMENTS

1. There are various search options built in the CPP Portal, to facilitate bidders to search active tenders by several parameters. These parameters could include Tender ID, Organization Name, Location, Date, Value, etc. There is also an option of advanced search for tenders, wherein the bidders may combine a number of search parameters such as Organization Name, Form of Contract, Location, Date, Other keywords etc. to search for a tender published on the CPP Portal.

2. Once the bidders have selected the tenders they are interested in, they may download the required documents / tender schedules. These tenders can be moved to the respective 'My Tenders' folder. This would enable the CPP Portal to intimate the bidders through SMS / e-mail in case there is any corrigendum issued to the tender document.
3. The bidder should make a note of the unique Tender ID assigned to each tender, in case they want to obtain any clarification / help from the Helpdesk.

PREPARATION OF BIDS

1. Bidder should take into account any corrigendum published on the tender document before submitting their bids.
2. Please go through the tender advertisement and the tender document carefully to understand the documents required to be submitted as part of the bid. Please note the number of covers in which the bid documents have to be submitted, the number of documents - including the names and content of each of the document that need to be submitted. Any deviations from these may lead to rejection of the bid.
3. Bidder, in advance, should get ready the bid documents to be submitted as indicated in the tender document / schedule and generally, they can be in PDF / XLS / RAR / DWF/JPG formats. Bid documents may be scanned with 100 dpi with black and white option which helps in reducing size of the scanned document.
4. To avoid the time and effort required in uploading the same set of standard documents which are required to be submitted as a part of every bid, a provision of uploading such standard documents (e.g. PAN card copy, annual reports, auditor certificates etc.) has been provided to the bidders. Bidders can use "My Space" or "Other Important Documents" area available to them to upload such documents. These documents may be directly submitted from the "My Space" area while submitting a bid, and need not be uploaded again and again. This will lead to a reduction in the time required for bid submission process.

SUBMISSION OF BIDS

1. Bidder should log into the site well in advance for bid submission so that they can upload the bid in time i.e. on or before the bid submission time. Bidder will be responsible for any delay due to other issues.
2. The bidder has to digitally sign and upload the required bid documents one by one as indicated in the tender document.
3. Bidder has to select the payment option as "offline" to pay the tender fee/EMD as applicable and enter detail of the instrument.
4. Bidders should submit the EMD as per the instructions specified in the tender document. The original instrument should be posted/couriered/given in person to the Tender processing Section at the above address, latest by the last date of bid submission. The detail of the Demand Draft / any other accepted instrument, physically sent, should tally with the details available in the scanned copy and the data entered during bid submission time. Otherwise the uploaded bid will be rejected.
Exemption will be given to the MSME/NSIC registered agencies for submission of EMD.

5. A standard Price Schedule format (BOQ) has been provided with the tender document to be filled by all the bidders. Bidders are requested to note that they should necessarily submit their financial bids in the format provided and no other format is acceptable. If the price bid has been given as a standard BOQ format with the tender document, then the same is to be downloaded and to be filled by all the bidders. Bidders are required to download the BOQ file, open it and complete the white colored (unprotected) cells with their respective financial quotes and other details (such as name of the bidder). No other cells should be changed. **In case no rate value is required to be quoted in any particular cell, that cell must be kept blank, figure '0' (zero) shall not be entered in such cell(s).** Once the details have been completed, the bidder should save it and submit it online, without changing the filename. If the BOQ file is found to be modified by the bidder, the bid will be rejected.
6. The server time (which is displayed on the bidders' dashboard) will be considered as the standard time for referencing the deadlines for submission of the bids by the bidders, opening of bids etc. The bidders should follow this time during bid submission.
7. All the documents being submitted by the bidders would be encrypted using PKI encryption techniques to ensure the secrecy of the data. The data entered cannot be viewed by unauthorized persons until the time of bid opening. The confidentiality of the bids is maintained using the secured Socket Layer 128 bit encryption technology. Data storage encryption of sensitive fields is done. Any bid document that is uploaded to the server is subjected to symmetric encryption using a system generated symmetric key. Further this key is subjected to asymmetric encryption using buyers/bid openers public keys. Overall, the uploaded tender documents become readable only after the tender opening by the authorized bid openers.
8. The uploaded tender documents become readable only after the tender opening by the authorized bid openers.
9. Upon the successful and timely submission of bids (i. e. after Clicking "Freeze Bid Submission" in the portal), the portal will give a successful bid submission message & a bid summary will be displayed with the bid no. and the date & time of submission of the bid with all other relevant details.
10. The bid summary has to be printed and kept as an acknowledgement of the submission of the bid. This acknowledgement may be used as an entry pass for any bid opening meetings.

ASSISTANCE TO BIDDERS

1. Any enquiries relating to the tender document and the terms and conditions contained therein should be addressed to the Tender Inviting Authority for a tender or the relevant contact person indicated in the tender
2. Any queries relating to the process of online bid submission or queries relating to CPP Portal in general may be directed to the 24x7 CPP Portal helpdesk. The contact number for the helpdesk is 1800 233 7315.
3. Any queries relating to the Tender may be addressed to ansarimin@gmail.com, nscdelhi10@gmail.com with proper credentials of the bidders before the bid clarification date thereafter no queries will be entertained

NATIONAL SCIENCE CENTRE
(A Unit of National Council of Science Museums)
Bhairon Road, Near Gate No. 4, Pragati Maidan,
New Delhi – 110001

TENDER No. NSCD/18011/E-Tender -30/ 2024-25

GENERAL TERMS AND CONDITIONS FOR SUBMISSION OF TENDER

GENERAL TERMS & CONDITIONS (GTC) FOR SUBMISSION OF TENDER FOR **FABRICATION AND SUPPLY OF ALUMINIUM ANODIZED EXTRUDED EXHIBITION DISPLAY SECTIONS, SELF COLOUR STRICTLY AS PER CENTRE SPECIFICATIONS AND DRAWINGS.**

1. Bidders should have necessary infrastructure facilities and financial capability so as to take up the job of supply of the tendered items strictly as per the specifications, drawings and quantity mentioned in the BoQ and within the time frame mentioned at Sl. No. 04 below.
2. **Price:** The prices and rates indicated/quoted shall be inclusive of cost of materials, supply and all incidental charges to deliver the Aluminium Anodized Extruded Exhibition Display Sections at **Stores & Purchase Section, National Science Centre (A unit of NCSM), Pragati Maidan, Near Gate No.4, Pragati Maidan, New Delhi-110001.** The rate of GST to be imposed on the rate shall be clearly mentioned. **Rates may be quoted itemwise as per BoQ, however order will be placed with overall lowest Bidder for compatibility.** Prices and rate quoted shall be firm and fixed for the entire period of execution of the order and no escalation of rate on any ground whatsoever shall be applicable.
3. The successful bidders shall submit the Duplicate copy of the order duly signed and stamped as a token of acceptance of the same within 7(Seven) days from the date of Placement of the order.
4. Time is the essence of this tender. The delivery shall be made strictly as per following time frame :

Stage-I

10 pcs of samples of each tendered item strictly as per specifications and drawings should be got approved from NSCD authorities. For this purpose, the successful bidder shall submit 10 numbers of samples of each item for inspection and approval to National Science Centre, Delhi within 07 (Seven) days from the date of placement of order. The successful bidder shall have to take the entire responsibility to obtain necessary approval of the sample strictly within the above schedule failing which the order shall be cancelled without any further reference.

Stage-II

After obtaining samples approval from the authority of the Centre as detailed in Stage-I above, supply of the balance quantity of the tendered items, as per enclosed specifications and drawings, shall be made at **National Science Centre (A unit of NCSM), Pragati Maidan, Near Gate No.4, Pragati Maidan, New Delhi-110001.** strictly within 30 (thirty) days from the date of approval of samples. Please note that the time frame for getting the samples approved and supply of the entire quantity of all the tendered items at **NSCD is 37 days** from the date of placement of the order.

For non-compliance of any of the above terms and non-delivery of the tendered items, complete in all respects within the above stipulated delivery period, the Centre shall have the right either to cancel the order or impose penalty as detailed in Clause No.05. Decision in this regard taken by the Centre shall be final and binding on the successful bidder.

5. **Penalty Clause:** - The time allowed for executing the supply as detailed in Clause No.04 shall be strictly observed by the successful bidder. The supply shall throughout the stipulated period of the order, be proceeded with all the diligence (time being deemed to be the essence of the order) and the successful bidder shall pay to the Centre, an amount equal to 1% of the amount of the contract value for every week that the supply may remain incomplete as per delivery schedule as stipulated in Clause No.04 subject to a maximum compensation of 10% of the contract value after which period, action will be taken by the Centre as will deem fit.

The Centre may extend the time of delivery of the ordered items at their discretion on the application of the successful bidder for such purpose provided that the Centre considers the reasons for such extension as good, sufficient and acceptable.

6. Every effort should be made to complete the supply by the successful bidder within the specified time schedule. In case the firm fails to comply with Clause No.04 within the specified time schedule as per the finalized and accepted terms & conditions, the Centre shall have the right to either impose penalty clause or cancel the order forthwith. The decision of the Centre in this regard shall be final and binding on the successful bidder. **Please note that the successful bidder shall supply the ordered materials without any change in specification/drawing or quantity.**
7. **Payment Terms:-**No advance payment shall be made by the Centre on any circumstances. Payment shall be released within 30(thirty) working days from the date of receipt of Invoice/Bill(supplies covered under Stage-II of clause No.04) duly supported by receipted challan subject to satisfactory inspection report of the ordered materials issued by the competent authority of the Centre.
8. **Warranty:** Manufacturer's standard warranty should be offered by the bidder. The bidder shall be responsible for all defects of materials including defective workmanship, use of defective materials etc. for the entire warranty period of the manufacturer effective from the date of final acceptance of the ordered materials.
9. The materials to be supplied by the bidder shall conform to the drawings and specifications given by the Centre. Sub-standard quality of materials & workmanship will not be accepted. The samples must be got approved well in advance from the competent authority of the Centre.
10. The Centre shall not be liable for injury of any employees who are deployed by the bidder within/outside the Centre premises at the time of execution of the order.
11. **Colour Scheme:-** Self colour anodized (15 micron) Aluminium Anodized Extruded exhibition display Sections should be free from any waviness/dents/patch marks. The product should also be free from any embossed/etched/watermark/stickers of manufacture's logo or name.
12. Bad workmanship will not be accepted and if carried out is liable to be rejected and should be rectified by the supplier at his own cost & risk as per specifications and directions given by the authorized representative of the Centre.
13. If it is noticed that the goods supplied do not conform to the specification/drawing of the order, the Centre shall have the right to reject the materials in part or full. The supplier shall be liable to replace the rejected materials within the stipulated time. Till the replacement is done, the rejected materials shall be lying at the risk, cost and responsibility of the supplier. If the supplier does not arrange to replace the rejected materials within the stipulated time, the same may be disposed off at

the risk of the supplier and in the manner which the Centre will deem fit. The Centre shall be entitled to retain the proceeds of the disposal either in part or in full towards expenses incurred on storage, handling and disposal of the materials. The Centre shall also be entitled to recover the expenses made by them on account of storage & handling of such rejected goods till the goods are removed from the premises of the Centre.

14. In case the bidder refuse to accept the offer after finalization or does not comply with the Clause No.03 within 07 (Seven) days from the date of placement of the order as per the finalized and accepted terms & conditions, the order shall be cancelled forthwith.
15. The authorities of the National Science Centre, Delhi reserves the right to amend, alter or modify the terms & condition mentioned above if necessary from time to time.
16. The authorities of National Science Centre, Delhi, who does not bind themselves to accept the lowest tender, reserves the right to reject or accept any or all tenders wholly or partially without assigning and reason whatsoever.
17. The quantities specified in the tender may be decreased or increased at the sole discretion of NSCD authorities.
18. All disputes and differences between the successful bidder and the Centre of any kind except quality of workmanship and materials whatever arising out of or in connection with the order on carrying out the supply (whether during the progress of the work or after their completion and whether before or after the determination, abandonment or breach of the Terms & conditions of the order) shall be referred to the sole arbitration of a person nominated by the Director General, National Council of Science Museums, whose decision in this regard will be final and binding on both the successful bidder and the Centre.

The provisions of the Arbitration and Reconciliation Act 1996 or any statutory modification or re-enactment thereof and of the rules made there under for the time being in force shall apply to arbitration's proceedings under this Clause.

19. **FORCE MAJEURE**

Neither party shall bear responsibility for the complete or partial non-performance of any of its obligations (except for failure to pay any sum which has become due on account of receipt of goods under the provisions of the present contract), if the non-performance results from such Force Majeure circumstances as Flood, Fire, Earth Quake and other acts of God as well as War, Military operation, blockade, Acts or Actions of State Authorities or any other circumstances beyond the parties control that have arisen after signing of the present contract. In such circumstances the time stipulated for the performance of an obligation under the present contract is extended correspondingly for the period of time of action of these circumstances and their consequences.

19. **Make in India (MII)**

The tender abide with GOI order date 15th June 2017 to give purchase preference to Make In India (MII) product mentioned in order. Document link as follows:

https://dpiit.gov.in/sites/default/files/publicProcurement_MakeinIndia_15June2017.pdf

NATIONAL SCIENCE CENTRE
(A Unit of National Council of Science Museums)
Bhairon Road, Near Gate No. 4, Pragati Maidan,
New Delhi – 110001

NOTICE INVITING E-TENDER

TENDER No. NSCD/18011/E-Tender -30/ 2024-25

DECLARATION-I

This is to certify that I/We have no close relative as an employee of the National Science Centre, Delhi (close relatives means: Father, Mother, Brother, Sister, Son, Daughter and Spouse) nor any such close relatives are associated with us as proprietor/partner/shareholder/ Director and like.

Signature of the Bidder / Constituted Attorney.

DECLARATION-II

We do hereby accept the “General Terms & Conditions” as provided by the National Science Centre, Delhi along with the tender documents for Supply of Aluminium Anodized Extruded Exhibition Display Sections, Self colour and also under take to supply the said materials strictly as per the drawings and specifications of National Science Centre, Delhi as provided along with the tender documents, in the event of placement of any order on us. The Centre shall be at liberty to cancel the order in full or in part in the event of failure of any of the above declaration made by us.

Signature of the Bidder / Constituted Attorney.

NATIONAL SCIENCE CENTRE
(A Unit of National Council of Science Museums)
Bhairon Road, Near Gate No. 4, Pragati Maidan,
New Delhi – 110001

TENDER No. NSCD/18011/E-Tender -30/ 2024-25

TECHNICAL (Techno-Commercial) BID

Notes: ALL PARTICULARS / INFORMATIONS SHOULD BE GIVEN IN THE FOLLOWING FORMAT WITH COMPLETE DETAILS.

1.	Name & Address of the Firm/Bidder	:	
2.	Telephone Number	:	
	Office		
	Workshop		
	Email Id		
	Name and Mobile No. of Contact Person		
3. (i)	Background detail of the Firm	:	
	(State whether original manufacturer/Direct dealer of the manufacturer		
(ii).	In case of direct dealers, submit copy of valid dealership license issued by the manufacturer.		
4.	Past experience in such business for last 03 years giving details of established clients especially Government Offices. Submit satisfactory certificate issued by such clients and Government Offices. Submit the copies of Purchase Orders regarding execution of latest contract of similar items for a minimum single order of Rs.03.00 Lakhs.	:	
5. (i)	Whether capable to supply the tendered Aluminium Anodized extruded Section (SIMA) Self Colour strictly as per enclosed drawing and technical specifications and time frame (Please mention 'YES' or 'NO'.)	:	
(ii)	If it is mentioned 'NO' above, submit detailed deviation to be made from the enclosed technical specification.		
(iii)	If it is mentioned 'YES' above submit copies of product brochure (for product categories) as a proof of their statement.		

(iv)	State whether the Aluminium Anodized extruded Section (SIMA) Self Colour to be offered by the firm either come with or in compliance with all the features as detailed in enclosed specifications & drawings. (State 'YES' or 'NO').		
6.	State the Name & Address of the Manufacturer whose product has been offered/quoted by the tenderer.	:	
7.	Proof of financial status of the company/audited balance sheet for last 03 years indicating the total turnover as well. Submit the documentary evidence.	:	
8.	Whether agreed to accept 30 days credit payment terms (Please mentioned 'YES' or 'NO').	:	
9.	Minimum time required to supply the tendered items at National Science Centre, Delhi.	:	
10.	Mention GST Registration Number and attach current valid GST Registration Certificate.	:	
11.	Whether agreed to get the sample of all the tendered items approved within 07 (Seven) days from the date of placement of order and supply the balance quantity of all the tendered items as per enclosed drawings and specifications positively within 30 (Thirty) days from the date of placement of order failing which ready to absorb heavy penalty, if any, if order is placed on the bidder after observing due tender procedure. (Please mention 'YES' or 'NO').	:	

I/We hereby declare that the above statements are true. I/We also declare that the decision of National Science Centre, Delhi regarding selection of eligible firms for opening of Financial Bid (Part-II) shall be final and binding on me/us.

Dated

Official Seal
Signature of the Tenderer/Constituted Attorney

NATIONAL SCIENCE CENTRE
(A Unit of National Council of Science Museums)
Bhairon Road, Near Gate No. 4, Pragati Maidan,
New Delhi – 110001

BOQ PERFORMA

Validate

Print

Help

Tender Inviting Authority: < Director, National Science Centre, Delhi >									ANNEXURE- E
Name of Work: < Fabrication and Supply of Aluminium Anodized Extruded Display Sections (SIMA) – Self Color Strictly at National Science Centre, Delhi as mentioned in Annexure-F>									
Contract No: <NSCD/180111//E-Tender-30/2024-25>									
Name of the Bidder/ Bidding Firm / Company									
PRICE SCHEDULE									
(DOMESTIC TENDERS - RATES ARE TO GIVEN IN RUPEES (INR) ONLY)									
(This BOQ template must not be modified/replaced by the bidder and the same should be uploaded after filling the relevant columns, else the bidder is liable to be rejected for this tender. Bidders are allowed to enter the Bidder Name and Values only)									
NUMBER #	TEXT #	TEXT #	NUMBER #	TEXT #	NUMBER #	NUMBER	NUMBER #	NUMBER #	TEXT #
Sl. No.	Item Description	Length (L)	Quantity	Units	BASIC RATE In Figures To be entered by the Bidder in Rs. P	GST Rate in Percentage %	TOTAL AMOUNT Without Taxes col (13) = (4) x (7) in Rs. P	TOTAL AMOUNT With Taxes col (14) = sum (8) to (13) in Rs. P	TOTAL AMOUNT In Words
1	2	3	4	5	7	9	13	14	15
1	Fabrication and Supply of Aluminium Anodized Extruded Display Sections (SIMA) – Self Color Strictly at National Science Centre, Delhi as per Annexure-F								
1.01	Square Vertical (SV-8) <2440mm>	Item 1	250.00	Nos.			0.00	0.00	INR Zero Only
1.02	Octagonal Vertical (OV-8) <2440mm>	Item 2	30.00	Nos.			0.00	0.00	INR Zero Only

1.03	Hexagonal Vertical (HV-8) <2440mm>	Item 3	36.00	Nos.			0.00	0.00	INR Zero Only
1.04	Horizontal Plain (H-2) <588mm>	Item 4	250.00	Nos.			0.00	0.00	INR Zero Only
1.05	Horizontal Plain (H-4) <1206mm>	Item 5	200.00	Nos.			0.00	0.00	INR Zero Only
1.06	Horizontal Single Web (HSW-2) <588mm>	Item 6	250.00	Nos.			0.00	0.00	INR Zero Only
1.07	Horizontal Single Web (HSW-4) <1206mm>	Item 7	200.00	Nos.			0.00	0.00	INR Zero Only
1.08	Horizontal Double Web (HDW-2) <588mm>	Item 8	24.00	Nos.			0.00	0.00	INR Zero Only
1.09	Horizontal Double Web (HDW-4) <1206mm>	Item 9	24.00	Nos.			0.00	0.00	INR Zero Only
1.10	Lock Assembly	Item 10	3000.00	Nos.			0.00	0.00	INR Zero Only
Total in Figures							0.00	0.00	INR Zero Only
Quoted Rate in Words		INR Zero Only							

NATIONAL SCIENCE CENTRE
(A Unit of National Council of Science Museums)
Bhairon Road, Near Gate No. 4, Pragati Maidan,
New Delhi – 110001

TENDER No. NSCD/18011/E-Tender -30/ 2024-25

DRAWINGS & TECHNICAL SPECIFICATIONS

Aluminium Anodized Extruded Section (SIMA)-Self Colour.

Sr. No.	Type of Aluminium Section/Item Name	Length (L)	Required Quantity
1.	Square Vertical (SV-8)	2440 mm	250 Nos.
2.	Hexagonal Vertical (HV-8)	2440 mm	36 Nos.
3.	Octagonal Vertical (OV-8)	2440 mm	30 Nos.
4.	Horizontal Plain (H-2)	588 mm	250 Nos.
5.	Horizontal Single Web (HSW-2)	588 mm	250 Nos.
6.	Horizontal Double Web (HDW-2)	588 mm	24 Nos.
7.	Horizontal Plain (H-4)	1206 mm	200 Nos.
8.	Horizontal Single Web (HSW-4)	1206 mm	200 Nos.
9.	Horizontal Double Web (HDW-4)	1206 mm	24 Nos.
10.	Lock Assembly		3000 Nos.

Aluminium Extruded Display Sections (SIMA) – ‘Self Color Anodized’

ALUMINUM ALLOY: 6063-T5

Properties	Metric
Density	2.70 g/cc
Hardness, Brinell	60
Ultimate Tensile Strength	186 MPa
Tensile Yield Strength	145 MPa
Elongation at Break (Typical; 1/16 in. (1.6 mm) Thickness)	12.00%
Modulus of Elasticity	68.9 GPa
Poissons Ratio	0.33
Fatigue Strength	68.9 MPa
Electrical Resistivity	0.00000316 ohm-cm @Temperature 20.0°C
Average CTE	23.4 µm/m-°C @Temperature 20.0 - 100°C
Specific Heat Capacity	0.900 J/g-°C
Thermal Conductivity	209 W/m-K
Melting Point	616 - 654 °C

Specifications:-

- Dimension : Strictly as per drawing.
- Finish: Self-Colour anodized (15 micron)
- Surface should be free from any waviness/dents/patch marks.
- Surface should be free from any embossed/etched/watermark/strickers of manufacture’s logo or name.
- All sections should be supplied with individual transparent reusable protective wrapper.

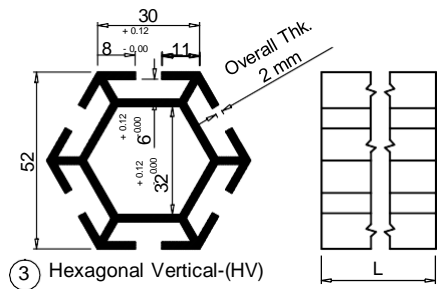

③ Hexagonal Vertical-(HV)

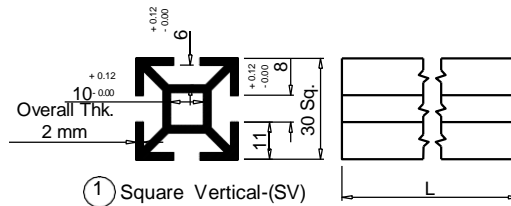

① Square Vertical-(SV)

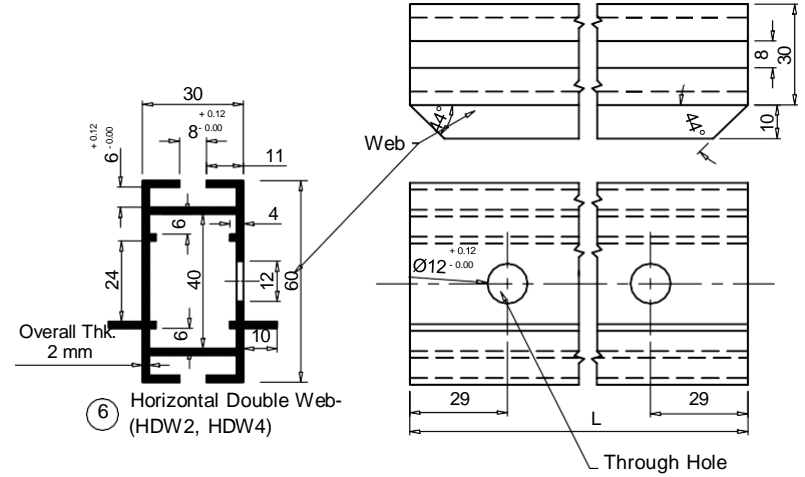

⑥ Horizontal Double Web-(HDW2, HDW4)

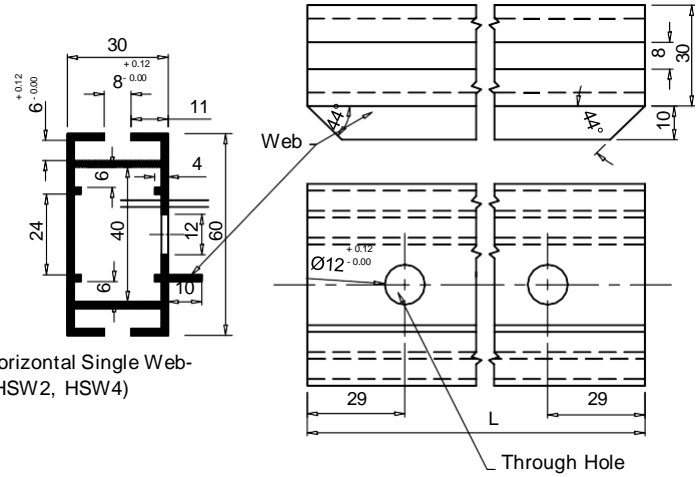

⑤ Horizontal Single Web-(HSW2, HSW4)

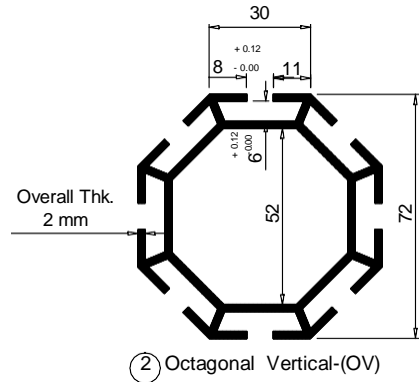

② Octagonal Vertical-(OV)

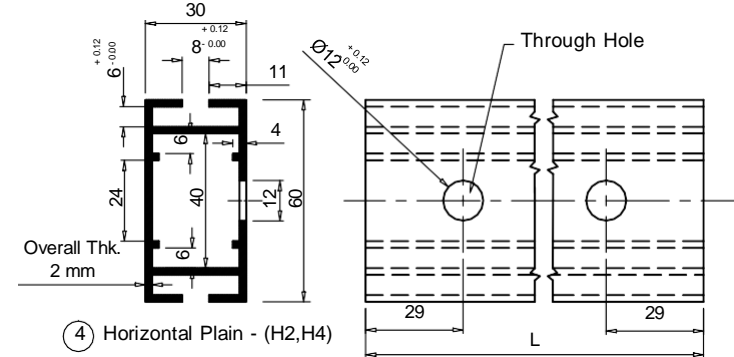

④ Horizontal Plain - (H2,H4)

SL.NO.	ITEM.NO.	CODE	SECTION	LENGTH (L)	QUANTITY
1	①	SV 8	Square Vertical	2440 mm	250 nos.
2	②	OV 8	Octagonal Vertical	2440 mm	30 nos.
3	③	HV8	Hexagonal Vertical	2440 mm	36 nos.
4	④	H2	Horizontal Plain	588 mm	250 nos.
5	④	H4	Horizontal Plain	1206 mm	200 nos.
6	⑤	HSW2	Horizontal Single Web	588 mm	250 nos.
7	⑤	HSW4	Horizontal Single Web	1206mm	200 nos.
8	⑥	HDW2	Horizontal Double Web	588 mm	24 nos.
9	⑥	HDW4	Horizontal Double Web	1206 mm	24 nos.

Note :
 1. All Dimensions are in mm
 2. Finish : Aluminium self coloured Anodized.(out side of the section) thickness of Anodized 15 Micron
 3. Both end of the section should be free from bars.

NATIONAL COUNCIL OF SCIENCE MUSEUMS

UNIT: NSCD		PROJ.- NSCD	
DRG. NO. MECH-03/07/19	DATE 22/08/2023	SCALE N.T.S.	TOLERANCE ±0.25mm NO OFF.
Al. Extruded Section			All dimensions are in mm
DRN. BY MINAKSHI DUTTA	CKD. BY	APPRD. BY	

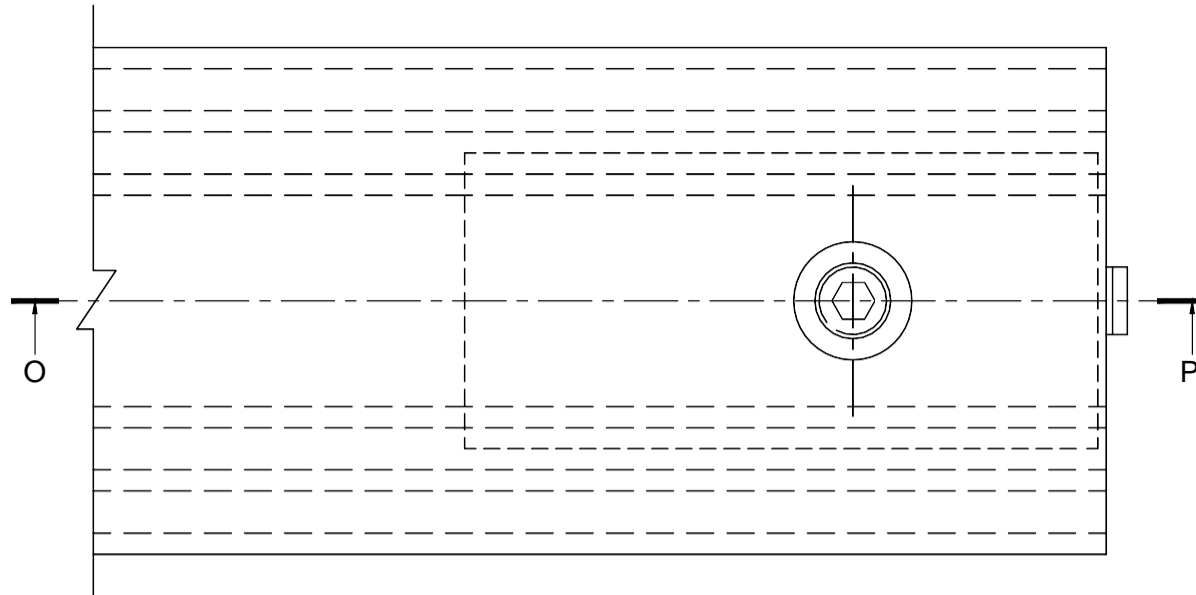

- ① PIN GUIDE
- ② PIN CARRIER
- ③ COMPRESSION SPRING
- ④ PIN
- ⑤ ALLEN HEAD GRUB SCREW
- ⑥ HORIZONTAL BAR

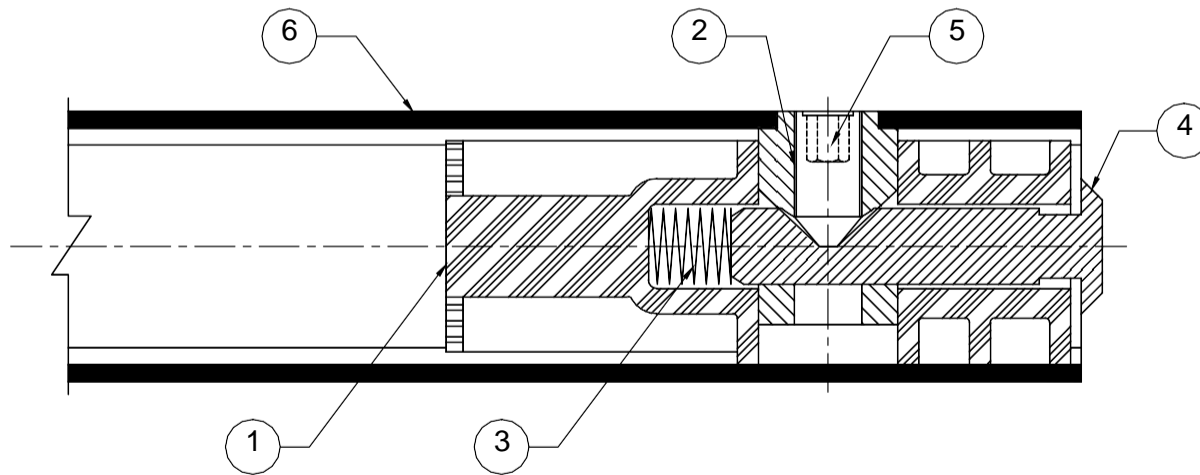

SECTION - OP

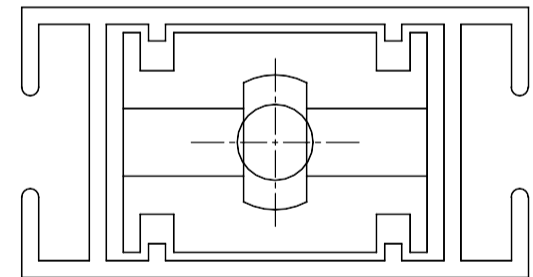

			
NATIONAL COUNCIL OF SCIENCE MUSEUMS			
UNIT: NSCD		PROJ.- NSCD	
DRG. NO.	DATE	SCALE	TOLERANCE
MECH-05/48/15/C	16/10/15	1 : 1	± 0.25mm
TITLE:- LOCK ASSEMBLY			NO OFF.
DRN. BY	CKD. BY	APPRD. BY	
MINAKSHI SUR			

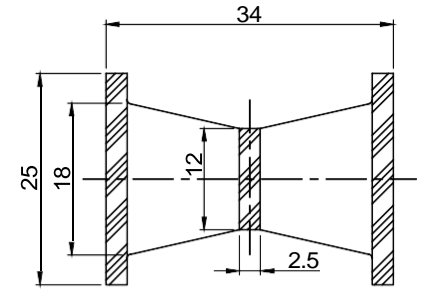
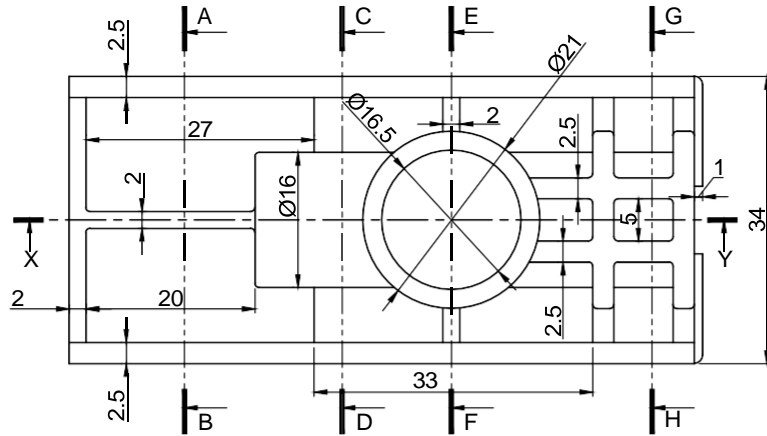

SEC - AB

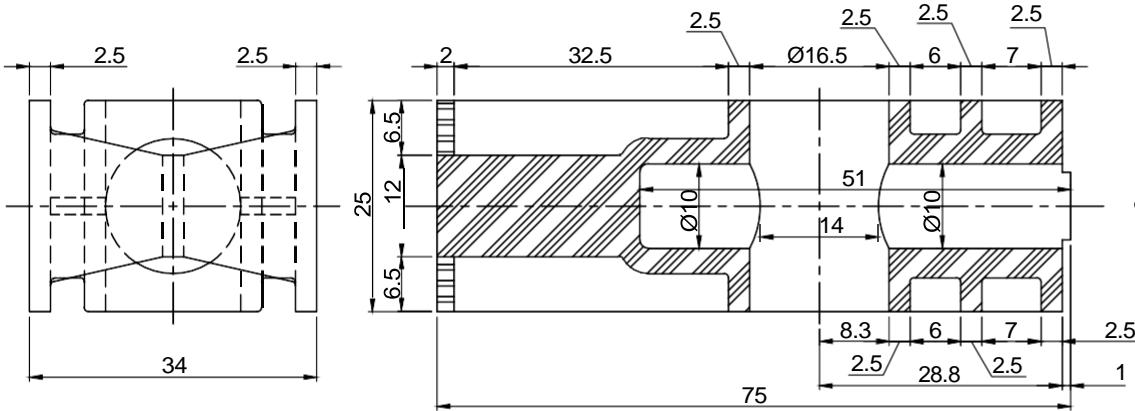

SEC - XY

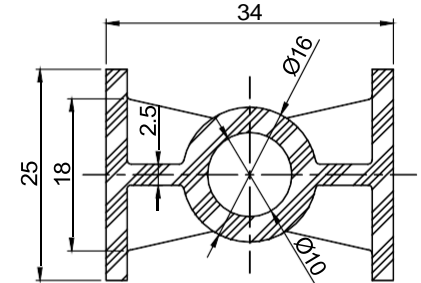
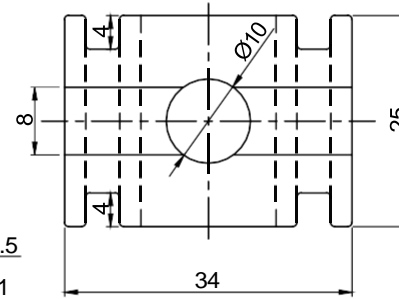

SEC - CD

1 PIN GUIDE

MATERIAL:- DERLIN (WHITE)

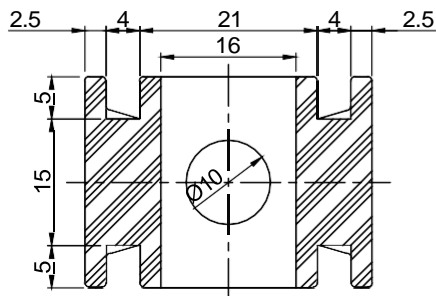

SEC - EF

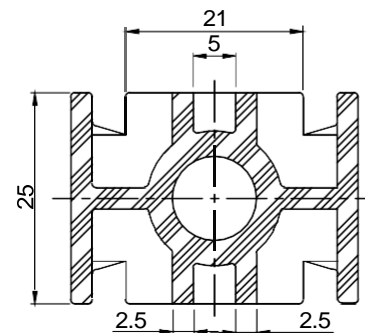

SEC - GH

NATIONAL COUNCIL OF SCIENCE MUSEUMS				
UNIT: NSCD		PROJ.- NSCD		
DRG. NO. MECH-05/48/15/A	DATE 16/10/15	SCALE 1 : 1	TOLERANCE ± 0.25mm	
TITLE:- LOCK PIN GUIDE Details			NO OFF.	
DRN. BY MINAKSHI SUR	CKD. BY	APPRD. BY		

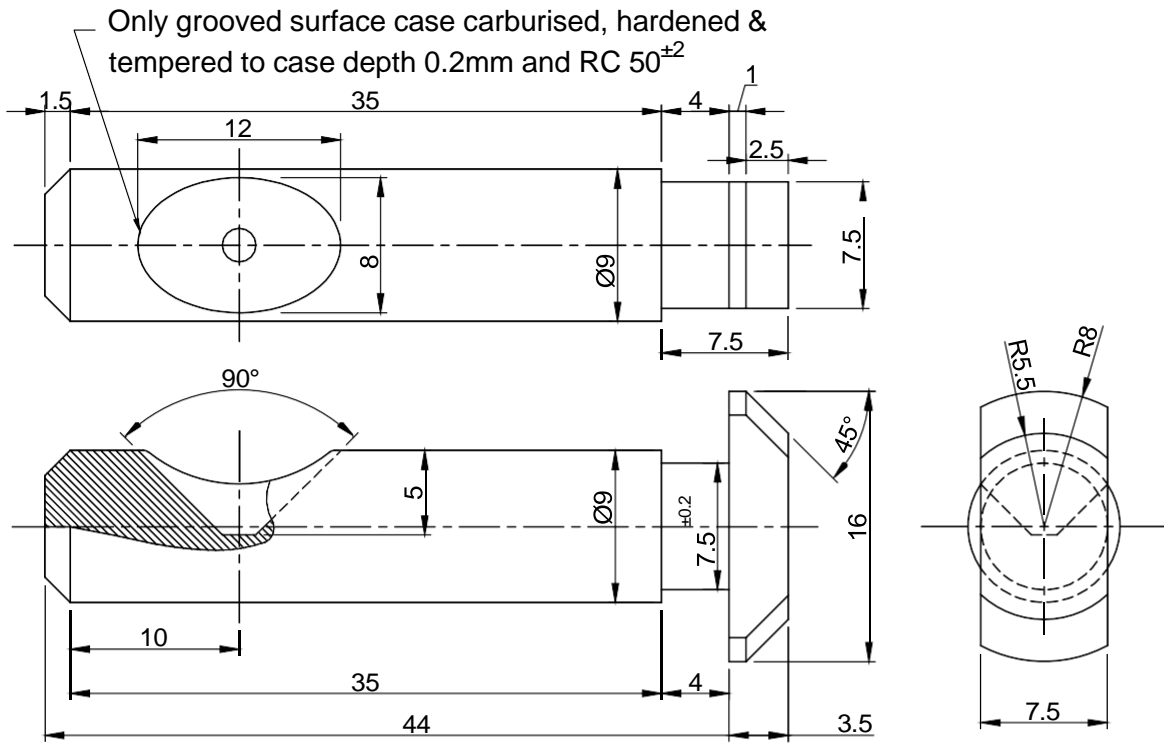

Material :- EN1A
Zn plated

4 PIN

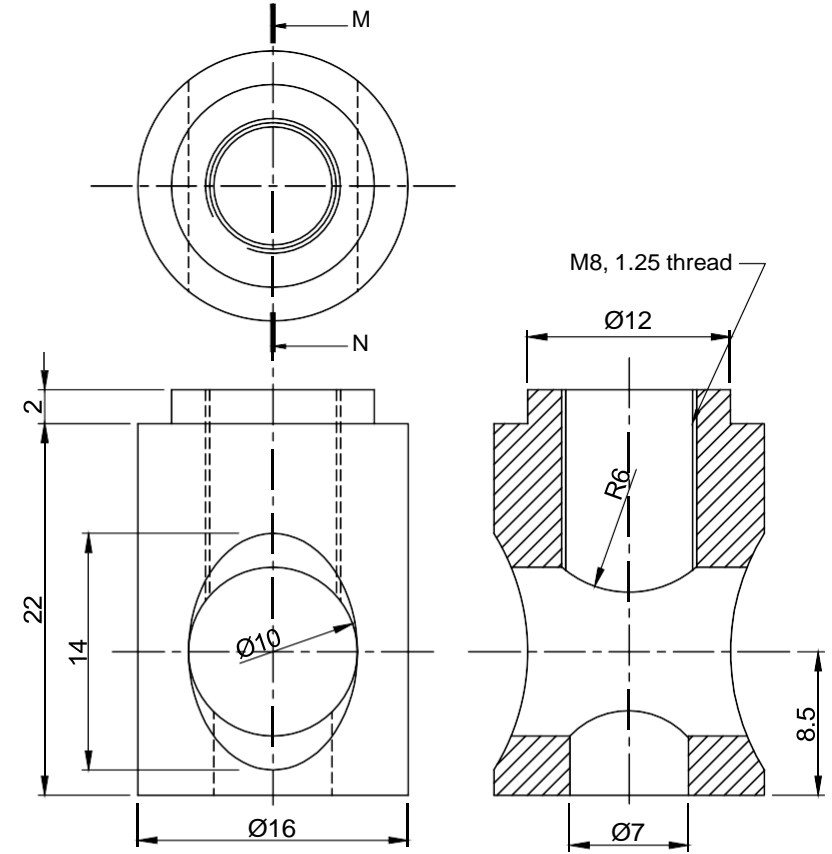

Material :- C.R.M.S.
Zn plated

SEC - MN

2 PIN CARRIER

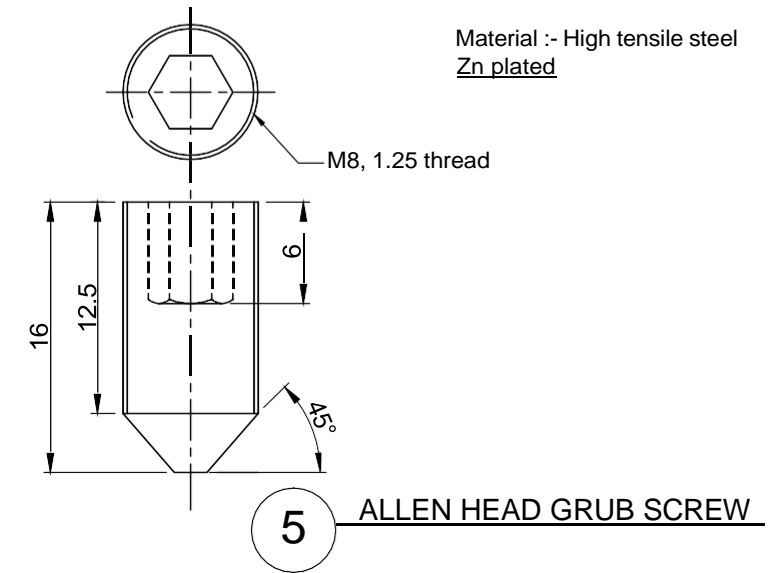

Material :- High tensile steel
Zn plated

5 ALLEN HEAD GRUB SCREW

Material :- Spring steel wire.
Hardened & tempered
Zn plated

Wire dia. - 20 gauge
No. of coil - 7
Compressive spring

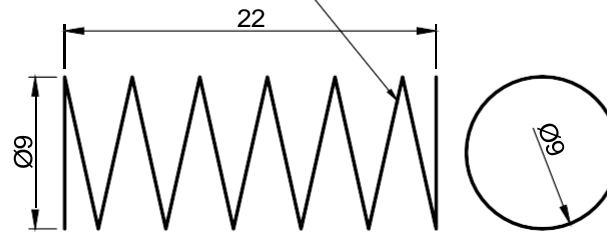

3 COMPRESSION SPRING

			
NATIONAL COUNCIL OF SCIENCE MUSEUMS			
UNIT: NSCD		PROJ.- NSCD	
DRG. NO. MECH-05/48/15/B	DATE 16/10/15	SCALE 1 : 1	TOLERANCE ± 0.25mm
TITLE:- LOCK PIN Details			NO OFF.
DRN. BY MINAKSHI SUR	CKD. BY	APPRD. BY	

NATIONAL SCIENCE CENTRE
(A Unit of National Council of Science Museums)
Bhairon Road, Near Gate No. 4, Pragati Maidan,
New Delhi – 110001

NOTICE INVITING E-TENDER

TENDER No. NSCD/18011/E-Tender -30/ 2024-25

BID SECURITY DECLARATION FORM

For Tender of Fabrication and Supply of Aluminium Anodized Extruded Section (SIMA)
Self Colour.

Date: _____

To
The Director
National Science Centre, Delhi
(A Unit of National Council of Science Museums)
Pragati Maidan, New Delhi.

I/We. the undersigned, declare that:

I/We understand that, according to your conditions, bids must be supported by a Bid Security Declaration.

I/We accept that I/We may be disqualified from bidding for any contract with you for a period of **three years** from the date of notification if I am /We are in a breach of any obligation under the bid conditions, because I/We

- a) . have withdrawn/modified/amended, impairs or derogates from the tender, my/our Bid during the period of bid validity specified in the form of Bid; or
- b) . having been notified of the acceptance of our Bid by the purchaser during the period of bid validity
 - (i) fail or refuse to execute the contract, if required, or
 - (ii) fail or refuse to furnish the Performance Security, in accordance with the RFP terms.

I/We understand this Bid Securing Declaration shall cease to be valid if I am/we are not the successful Bidder, upon the earlier of (i) the receipt of your notification of the name of the successful Bidder; or (ii) thirty days after the expiration of the validity of my/our Bid.

Signature of Authorized Person with Company Seal

**MANDATORY DOCUMENT TO BE FILED IN & SUBMITTED ALONG WITH THE BID
DULY SIGNED BY THE AUTHORIZED SIGNATORY**

Self – Certification under preference to Make in India Order Certificate

In line with Government Public Procurement Order No. P-45021/2/2017-PP (BE-II) dated 04.06.2020 issued by Ministry of Commerce and Industry and subsequent amendment of the Order dt .16th September , 2020, we hereby certify that –

We M/s _____ (Supplier name)

Are local supplier meeting the requirement of minimum local content(*) (I.e. amount of value addition) _____% as defined in above orders for the items/s against Bid/Tender No.:- _____.

Details/Breakup of local content & location at which local value addition is made for the item/s are as follows:

S. No.	Description of Item with local content	Qty.	Percentage of local content to Total Bid Price without levies (only % to be indicated)	Details of Location(S) where local value addition is made.

We also understand, false declarations will be in breach of the Code of Integrity under Rule 175(1)(i)(h) of the General Financial Rule for which for which a bidder or its successors can be debarred for up two (2) years as per Rule 151(iii) of the General Financial Rules along with such other actions as may be permissible under law.

I/We certify that Transportation, Insurance, Installation, Commissioning, Training & other after Sales Service Support like AMC/ CMC, etc., not claimed as a Local Value Addition.

Signature of the Vendor with Stamp

(*) Local Content: means the amount of value added in India i.e. total value of the item (excluding local taxes) minus the value of import content in the item (including customs duty) as a proportion of the total value of the item, in percent.

Noe: 1) Self declaration certificate should quantify the percentage of local content of the offered product only. It should also indicate the location. However, claiming the services such as transportation, insurance, installation & commissioning, training and after sale service support like AMC/CMC etc., shall not be considered as local content as per OM N.P-45021/102/2019-BE-II-Part(1)(E-50310) dated: 04/03/2021 issued by Ministry of Commerce and Industry, DPIIT.

NON-MENTION OF ANY OF THE REQUESTED INFORMATION OR INCORRECT FILLING (LIKE-WRONG BID NO. ETC.) WILL LEAD TO REJECTION OF BID.

Annexure to Bid Form: Eligibility Declarations

(To be submitted as part of tender / Technical Bid)

(On Company Letter Head)

(Along with supporting documents, if any)

Bid /Tender No.	
Tender Title	
Bidder's Name (Address and contact details)	
Bidder's Reference No.	
Date	

Restrictions on procurement from Bidders from a country or countries, or a class of countries under Rule 144(xi) of the General Financial Rules 2017.

“We have read the Clause regarding restrictions on procurement from a Bidder of a country which shares a land border with India; and solemnly certify that we are not from such a country or, if from such a country, we are registered with the Competent Authority (copy enclosed). We hereby certify that we fulfill all requirements in this regard and are eligible to be considered.”

Penalties for false or misleading declarations:

We hereby confirm that the particulars given above are factually correct and nothing is concealed and also undertake to advise any future changes to the above details. We understand that any wrong or misleading self-declarations by us would be violation of Code of integrity and would attract penalties as mentioned in this tender document, including debarment.

_____ (Signature with date)

(Name and designation)

Duly authorized to sign Bid for and on behalf of

(Name & address of the Bidder and Seal of Company)

NON-MENTION OF ANY OF THE REQUESTED INFORMATION OR INCORRECT FILLING (LIKE-WRONG BID NO. ETC.) WILL LEAD TO REJECTION OF BID.

ANNEXURE-J

BANK DETAILS OF NATIONAL SCIENCE CENTRE, DELHI

Name of the Account Holder	NATIONAL SCIENCE CENTRE, DELHI
Account No.	2417101004100
Bank Name	CANARA BANK
Bank Address	6, Bhagwan Das Road, New Delhi
IFSC Code	CNRB0002417
MICR Code	110015045
Type of Account	Saving Account
Branch Code	2417
GST No.	07AAAAN2541C1Z5