

**E -TENDER
FOR
SUPPLY OF VARIOUS SIZES
TOUCH & NON-TOUCH DISPLAY,
VIDEO WALL, INFORMATION KIOSK
ETC. FOR
COAL GALLERY AT
NATIONAL SCIENCE CENTRE,
DELHI.**



Ministry of Culture
Government of India

**NATIONAL SCIENCE CENTRE
(NATIONAL COUNCIL OF SCIENCE MUSEUMS)
BHAIRON ROAD, NEAR GATE NO - 4, PRAGATI MAIDAN
NEW DELHI - 110 001**

**NATIONAL SCIENCE CENTRE,
NEAR GATE NO - 4, PRAGATI MAIDAN,
BHAIRON MARG, NEW DELHI-110001**

TENDER No. NSCD/18011/E-Tender -16 / 2023 - 24

NOTICE INVITING E-TENDER

On-line Digitally signed E-Tenders are invited in two Bid Systems from Manufacturers / authorized dealers for “**Supply of various sizes touch & non-touch display, video wall, information kiosk etc. For Coal Gallery at National Science Centre, Delhi**”. The experienced / eligible manufacturers/reputed authorized dealers may download the tender documents from the Central Public Procurement Portal (CPPP): <http://eprocure.gov.in/eprocure/app>

| | |
|----------------------------------|---------------------------------------|
| Bid Document Published Date | 27 th July, 2023 (18:00) |
| Bid Document Download Start Date | 27 th July, 2023 (18:00) |
| Bid Clarification Start Date | 27 th July, 2023 (18:00) |
| Bid Submission Start Date | 27 th July, 2023 (18:00) |
| Bid Clarification End Date | 07 th August, 2023 (14:00) |
| Bid Submission End Date | 16 th August, 2023 (15:00) |
| Technical Bid Opening Date | 17 th August, 2023 (16:00) |
| Financial Bid Opening date | Shall be communicated later on |
| Estimated cost of work | ₹132.20 Lakhs including Tax |
| Earnest Money Deposit | ₹3,31,000/- |

The online bid, both Technical Bid and Financial Bid, should be uploaded by the due date and time as per the above schedule. The responsibility to ensure the same lies with the bidders. Off-line tenders shall not be accepted and no request in this regard will be entertained whatsoever. **Online Technical Bid will be opened at the first instance in National Science Centre, Delhi at 04:00 p.m. on 17th August, 2023 for Technical Evaluation as well as selection of technically acceptable offers.** In the second stage, the Financial Bids of only the selected and techno-commercially acceptable offers / system / equipment will be opened. Decision of the Centre, regarding selection of eligible and qualified vendors / firms for opening the Financial Bid shall be final and binding on the bidders. Bidders may be present during opening of tenders.

NSC, Delhi reserves the right to accept or reject any or all tenders in full or part without assigning any reason whatsoever. NSCD shall also not be bound to accept merely the lowest tender but the technical suitability, capability and superiority of the equipment / system as well as after-sales service including infrastructure to render such service, etc. shall be of prime consideration for selection of the equipment /system.

CHECK LIST

Check list of Tender No. NSCD/18011/E-Tender - 16/ 2023 - 24 for “Supply of various sizes touch & non-touch display, video wall, information kiosk etc. For Coal Gallery at National Science Centre, Delhi”

| Sl. No. | Description | Yes | No |
|---------|--|-----|----|
| 01 | Whether E-Tender uploaded on Central Public Procurement Portal of Govt. of India (i.e. Technical & Commercial) separately. | | |
| 02 | Whether Tender documents are carefully studied & understood. | | |
| 03 | Whether Tender documents duly signed and stamped on all pages is scanned and uploaded as Part - I of the Tender in the central public procurement portal. | | |
| 04 | Whether Earnest Money of ₹3,31,000/- submitted by online / vide Demand Draft No. dated..... and Scanned copy of DD uploaded as Part - I of the Tender. Please note that the original DD should be couriered /hand delivered to NSC Delhi / online payment details shall be sent to NSCD before the time of opening Technical Bid. | | |
| 05 | Whether Declaration regarding Non-relation, duly signed and stamped, and scanned copy of the same uploaded as Part - I of the Tender in central public procurement portal. Annexure-C | | |
| 06 | Whether Declaration certifying that there are no extra conditions quoted in the Offer Form duly signed and stamped, and scanned copy of the same uploaded as Part - II of the Tender in central public procurement portal. Annexure-C | | |
| 07 | Did you visit the actual site for execution of the supply order before submitting the Tender | | |
| 08 | Authorization Letter issued from OEM enclosed with the Technical Bid. | | |

Date:

Signature of the Tenderer

Place:

Official Seal

General Information and Instructions

1. The instruction given herein will be strictly binding on the tenderers and deviation, if any will make the tender or tenders liable to be considered invalid. Tenders incorporating additional conditions by the tenderer are liable for rejection.
2. Bids shall be submitted online only at CPPP website: <https://eprocure.gov.in/eprocure/app> Manual bids shall not be accepted.
3. The instruction given in “**Annexure-A**” for “**Instruction for Online Bid Submission**” should be strictly followed during submission of the Bid.
4. Bid documents may be scanned with 100 dpi with black and white option which helps in reducing size of the scanned document.
5. Bid should be submitted along with the **Earnest Money of ₹3,31,000/- (Three Lakh Thirty One Thousand only)** through NEFT/RTGS in the account of National Science Centre as per Annexure-F or by way of crossed Demand Draft / Pay Order on any nationalized bank of India payable in favour of “**NATIONAL SCIENCE CENTRE, Payable at DELHI**”. Earnest Money deposit in the form of Bank Guarantee /Bond or any other instrument shall not be accepted and shall be rejected straightway. Earnest Money deposits in respect of such offers which are not accepted will be returned to the bidders within 30 working days from the date on which the final decision is taken about the source from which the items under tender are to be procured or within 2 (two) months from the date of the opening of the tenders, whichever is earlier. No interest will be paid on the Earnest Money deposited with the Council. Earnest Money deposit in respect of the successful bidders will be retained with the NSCD until entire execution of the order as per terms of the tender. If the successful bidder fails to execute the order strictly as per the NSCD’s specification in full or part within the stipulated delivery period of the purchase order, the Earnest Money deposit retained with the NSCD shall be forfeited forthwith after cancellation of the concerned order.
6. No exemption will be allowed for submission of Security Deposit/Retention Money to NSIC/MSME certified firms. **However, concession for submission of EMD shall be applicable to the Tenderers/Bidders registered with NSIC/MSME as per prevailing Govt. guidelines. The Tenderers/Bidders should upload document of the firm** for claiming such exemption. Tenderer/Bidder must upload signed Annexure-C-1, if the bidder is registered under NSIC/MSME.
7. **Validity of Bids:** The Bids should remain valid for 90 days from the date of bid opening.
8. **Rejection of Bids:** Canvassing by the Bidder in any form, unsolicited letter and post-tender correction may invoke summary rejection. Conditional tenders will be rejected. Non-compliance of applicable General Information and Instruction will disqualify the Bid.
9. The bidders should have Digital Signature Certificate (DSC) for filling up the Bids. The Person signing the tender documents should be authorized for submitting the online e-tender.
10. The Financial Bid (BOQ) shall be filled in and signed by the authorized signatory online as per Proforma “**Annexure-G**” available at Central Public Procurement Portal e-tender system website <http://eprocure.gov.in/eprocure/app>. Off line Financial Bid shall not be accepted.
11. **Tenders must be uploaded on-line in two separate sets - namely Set - 1 (Technical) on Central Public Procurement Portal. The contents of Cover shall be as follows:-**

Set - 1

- i) Tender Document uploaded with digital signature as token of acceptance of all terms and conditions and duly filled wherever applicable ('Declaration' forms duly signed with official stamp).
- ii) The Bidder must furnish details of GST Number and PAN Number (mandatory) and also upload the scanned copy of these documents in e-procure portal.
- iii) Scanned Copy of the current and valid Trade License and Dealership Certificate as applicable.
- iv) Scanned Copy of the current and valid Tax Clearance Certificate.
- v) Technical Brochures of each equipment with technical explanation for every feature of the product offered by the bidder.
- vi) Scanned copy of Demand Draft for ₹3,31,000/- as Earnest Money Deposit or scanned copy of MSME certificate for exemption of EMD.

Set - 2

- i) **The Financial Bid (as per Annexure-G) i.e. Schedule of Price Bid in the form of attached BOQ Proforma shall be duly filled in, digitally signed and uploaded online by the bidder.**

N.B. : The bidders shall consider the prevailing tax rates while quoting the rates. However, In the event of any changes in the statutory taxes and duties, the rates applicable at the time of payment shall be made by the competent authority of the NSC, Delhi against submission of supporting documentary evidence.

11. Order shall be placed in favour of the bidder whose technical bid is acceptable and offered lowest rate in **INDIVIDUAL** item(s) as per BOQ in Annexure - G.
12. The authority of National Science Centre, Delhi who does not bind themselves to accept the lowest tender and reserves the right to reject or accept any or all tenders wholly or partially without assigning and reason whatsoever.

NATIONAL SCIENCE CENTRE
(A Unit of National Council of Science Museums)
Bhairon Road, Near Gate No. 4, Pragati Maidan,
New Delhi-110001

TENDER No. : NSCD/18011/E-Tender - 16/ 2023 - 24

Instructions for Online Bid Submission

1. The bidders are required to submit soft copies of their bids electronically on the CPP Portal, using valid Digital Signature Certificates. The instructions given below are meant to assist the bidders in registering on the CPP Portal, prepare their bids in accordance with the requirements and submitting their bids online on the CPP Portal.
2. More information useful for submitting online bids on the CPP Portal may be obtained at <https://eprocure.gov.in/eprocure/app>

REGISTRATION

- 1) Bidders are required to enroll on the e-Procurement module of the Central Public Procurement Portal (URL: <https://eprocure.gov.in/eprocure/app>) by clicking on the link “**Online bidder Enrollment**” on the CPP Portal which is free of charge.
- 2) As part of the enrolment process, the bidders will be required to choose a unique username and assign a password for their accounts.
- 3) Bidders are advised to register their valid email address and mobile numbers as part of the registration process. These would be used for any communication from the CPP Portal.
- 4) Upon enrolment, the bidders will be required to register their valid Digital Signature Certificate (Class II or Class III Certificates with signing key usage) issued by any Certifying Authority recognized by CCA India (e.g. Sify / nCode / eMudhra etc.), with their profile.
- 5) Only one valid DSC should be registered by a bidder. Please note that the bidders are responsible to ensure that they do not lend their DSC's to others which may lead to misuse.
- 6) Bidder then logs in to the site through the secured log-in by entering their user ID / password and the password of the DSC / e-Token.

SEARCHING FOR TENDER DOCUMENTS

- 1) There are various search options built in the CPP Portal, to facilitate bidders to search active tenders by several parameters. These parameters could include Tender ID, Organization Name, Location, Date, Value, etc. There is also an option of advanced search for tenders, wherein the bidders may combine a number of search parameters such as Organization Name, Form of Contract, Location, Date, Other keywords etc. to search for a tender published on the CPP Portal.
- 2) Once the bidders have selected the tenders they are interested in, they may download the required documents / tender schedules. These tenders can be moved to the respective ‘My Tenders’ folder. This would enable the CPP Portal to intimate the bidders through SMS /e-mail in case there is any corrigendum issued to the tender document.

- 3) The bidder should make a note of the unique Tender ID assigned to each tender, in case they want to obtain any clarification / help from the Helpdesk.

PREPARATION OF BIDS

- 1) Bidders should take into account any corrigendum published on the tender document before submitting their bids.
- 2) Please go through the tender advertisement and the tender document carefully to understand the documents required to be submitted as part of the bid. Please note the number of covers in which the bid documents have to be submitted, the number of documents - including the names and content of each of the documents that need to be submitted. Any deviations from these may lead to rejection of the bid.
- 3) Bidders, in advance, should get ready the bid documents to be submitted as indicated in the tender document / schedule and generally, they can be in PDF / XLS / RAR / DWF/JPG formats. Bid documents may be scanned with 100 dpi with black and white option which helps in reducing size of the scanned document.
- 4) To avoid the time and effort required in uploading the same set of standard documents which are required to be submitted as a part of every bid, a provision of uploading such standard documents (e.g. PAN card copy, annual reports, auditor certificates etc.) has been provided to the bidders. Bidders can use “My Space” or “Other Important Documents” area available to them to upload such documents. These documents may be directly submitted from the “My Space” area while submitting a bid, and need not be uploaded again and again. This will lead to a reduction in the time required for the bid submission process.

SUBMISSION OF BIDS

- 1) Bidders should log into the site well in advance for bid submission so that they can upload the bid in time i.e. on or before the bid submission time. Bidders will be responsible for any delay due to other issues.
- 2) The bidder has to digitally sign and upload the required bid documents one by one as indicated in the tender document.
- 3) Bidders should submit the EMD as per the instructions specified in the tender document. The original instrument should be posted/couriered/given in person to the Tender processing Section at the above address, latest by the last date of bid submission. The detail of the Demand Draft / any other accepted instrument, physically sent, should tally with the details available in the scanned copy and the data entered during bid submission time.
- 4) A standard Price Schedule format (BOQ) has been provided with the tender document to be filled by all the bidders. Bidders are requested to note that they should necessarily submit their financial bids in the format provided and no other format is acceptable. If the price bid has been given as a standard BOQ format with the tender document, then the same is to be downloaded and to be filled by all the bidders. Bidders are required to download the BOQ file, open it and complete the Light Blue colored (unprotected) cells with their respective financial quotes and other details (such as name of the bidder). No other cells should be changed. Once the details have been completed, the bidder should save it and submit it online, without changing the filename. If the BOQ file is found to be modified by the bidder, the bid will be rejected.
- 5) The server time (which is displayed on the bidders’ dashboard) will be considered as the standard time for referencing the deadlines for submission of the bids by the bidders, opening of bids etc. The bidders should follow this time during bid submission.

- 6) All the documents being submitted by the bidders would be encrypted using PKI encryption techniques to ensure the secrecy of the data. The data entered cannot be viewed by unauthorized persons until the time of bid opening. The confidentiality of the bids is maintained using the secured Socket Layer 128 bit encryption technology. Data storage encryption of sensitive fields is done. Any bid document that is uploaded to the server is subjected to symmetric encryption using a system generated symmetric key. Further this key is subjected to asymmetric encryption using buyers/bid openers public keys.
- 7) The uploaded tender documents become readable only after the tender opening by the authorized bid openers.
- 8) Upon the successful and timely submission of bids (i.e. after Clicking “Freeze Bid Submission” in the portal), the portal will give a successful bid submission message & a bid summary will be displayed with the bid no. and the date & time of submission of the bid with all other relevant details.
- 9) The bid summary has to be printed and kept as an acknowledgement of the submission of the bid. This acknowledgement may be used as an entry pass for any bid opening meetings.

ASSISTANCE TO BIDDERS

1. Any enquiries relating to the tender document and the terms and conditions contained therein should be addressed to the Tender Inviting Authority for a tender or the relevant contact person indicated in the tender.
2. Any queries relating to the process of online bid submission or queries relating to CPP Portal in general may be directed to the 24x7 CPP Portal helpdesk. The contact number for the helpdesk is 1800 233 7315.
3. Any queries relating to the Tender may be addressed to nscdelhi10@gmail.com , ashis.mondal07@gmail.com with proper credentials of the bidders before the bid clarification date thereafter no queries will be entertained.

NATIONAL SCIENCE CENTRE
(A Unit of National Council of Science Museums)
Bhairon Road, Near Gate No. 4, Pragati Maidan,
New Delhi-110001

TENDER No. : NSCD/18011/E-Tender - 16/ 2023 - 24

GENERAL TERMS & CONDITIONS (GTC) FOR SUBMISSION OF TENDER FOR SUPPLY OF VARIOUS SIZE TOUCH & NON-TOUCH DISPLAY, VIDEO WALL, INFORMATION KIOSK ETC. FOR COAL GALLERY AT NATIONAL SCIENCE CENTRE, DELHI.

1. Bidders should have necessary infrastructure and facilities so as to take up the supply of the tendered items strictly as per enclosed specifications with required financial capability.
2. **Price:**
The prices and rates indicated/quoted shall be inclusive of cost of materials, supply and all incidental charges to deliver the **Various Size Touch & Non-Touch Display, Video Wall, Information Kiosk Etc. at National Science Centre, Delhi.** GST and any other taxes/levies to be imposed on the rate shall be clearly mentioned. Price and rate quoted shall be firm and fixed for the entire period of execution of the order and no escalation of rate on any ground whatsoever shall be applicable.
3. The successful bidder shall submit the following documents within 03 (Three) days from the date of Placement of the order:-
 - i) Duplicate copy of the order duly signed and stamped as a token of acceptance of the order.
4. **TIME OF COMPLETION:** Time is the essence of this tender. The delivery of the tendered item as per enclosed technical specifications shall be made at **NATIONAL SCIENCE CENTRE, DELHI** strictly within **Thirty (30) days** from the date of placement of the order. For non-compliance of any of the above terms and non-delivery of the tendered items, complete in all respects within the above stipulated delivery period, the Centre shall have the right either to cancel the order or impose penalty as detailed in Clause No.05. Decisions in this regard taken by the NSCD shall be final and binding on the successful bidder.
5. **PENALTY CLAUSE:-**
The time allowed for executing the supply as detailed in Clause No.04 shall be strictly observed by the successful bidder. The supply shall throughout the stipulated period of the order, be proceeded with all the diligence (time being deemed to be the essence of the order) and the successful bidder shall pay to the Centre , an amount equal to 1% of the amount of the contract value for every week that the supply may remain incomplete as per delivery schedule as stipulated in Clause No.04 subject to a maximum compensation of 10% of the contract value after which period, action will be taken by the Centre as will deem fit.
The Centre may extend the time of delivery of the ordered items at their discretion on the application of the successful bidder for such purpose provided that the Centre considers the reasons for such extension as good, sufficient and acceptable.
6. Every effort should be made to complete the supply by the successful bidder within the specified time schedule. In case the firm fails to comply with Clause no. 4 Within the specified time schedule as per the finalized and accepted terms & conditions, the Centre shall have the right to either impose penalty clause or cancel the order forthwith and the earnest money deposit retained with the Centre shall be automatically forfeited.

7. PAYMENT TERMS:-

No advance payment shall be made by the Centre in any circumstances. Digital Payment (e-Payment) through RTGS/NEFT/TT/etc. shall be released within **30 (Thirty)** working days from the date of receipt of Tax-Invoice (supplies covered under clause No.04), duly supported by receipted challan subject to satisfactory inspection report of the ordered materials issued by the competent authority of the Centre. Invoice should be submitted indicating the Name of the Banker, IFSC Code, Account number, RTGS and Swift number of the banker, etc. for releasing e-payment to the supplier.

8. WARRANTY:

Manufacturer's standard onsite warranty for the equipment as per annexures should be offered by the bidder. The bidder shall be responsible for all defects of materials including transportation, etc. for the entire warranty period of the manufacturer effective from the date of final acceptance of the ordered materials.

9. The equipment to be supplied by the bidder shall conform to the technical specifications given by the Centre.
10. If it is noticed that the goods supplied do not conform to the technical specification of the order, the Centre shall have the right to reject the materials in part or full. The supplier shall be liable to replace the rejected materials within the stipulated time. Till the replacement is done, the rejected materials shall be lying at the risk, cost and responsibility of the supplier.
11. If the supplier does not arrange to replace the rejected materials within the stipulated time, the same may be disposed off at the risk of the supplier and in the manner which the Centre will deem fit. The Centre shall be entitled to retain the proceeds of the disposal either in part or in full towards expenses incurred on storage, handling and disposal of the materials. The Centre shall also be entitled to recover the expenses made by them on account of storage & handling of such rejected goods till the goods are removed from the premises of the Centre.
12. In case the bidder refuses to accept the offer after finalization or does not comply with the Clause No.03 within 03 (Three) days from the date of placement of the order as per the finalized and accepted terms & conditions and the order shall be cancelled forthwith.
13. The authorities of the National Science Centre, Delhi have the right to amend, alter or modify the terms & conditions mentioned above, if necessary, from time to time.
14. The authorities of National Science Centre, who do not bind themselves to accept the lowest tender, reserves the right to reject or accept any or all tenders wholly or partially without assigning any reason whatsoever.
15. The quantities specified in the tender may be decreased or increased at the sole discretion of NSCD authorities.
16. The agencies participating in the tenders & bidding may obtain on specific request, details about the outcome of the Tender and other related details, if any.
17. **Make in India (MII)**
The tender abide with GOI order date 15th June 2017 to give purchase preference to Make In India (MII) product mentioned in order. Document link as follows:
https://www.meity.gov.in/writereaddata/files/PPP_MII_Order_dated_16_09_2020.pdf
18. All disputes and differences between the successful bidder and the Centre of any kind except quality of workmanship and materials whatever arising out of or in connection with the order on carrying out the supply (whether during the progress of the work or after their completion and whether before or after the determination, abandonment or breach of the Terms & conditions of the order) shall be referred to the sole arbitration of a person nominated by the Director General, National Council of Science Museums, whose decision in this regard will be final and binding on both the successful bidder and the Centre.

The provisions of the Arbitration and Conciliation Act 1996 or any statutory modification or re-enactment thereof and of the rules made there under for the time being in force shall apply to arbitration's proceedings under this Clause.

19. FORCE MAJEURE

Neither party shall bear responsibility for the complete or partial non-performance of any of its obligations (except for failure to pay any sum which has become due on account of receipt of goods under the provisions of the present contract), if the non-performance results from such Force Majeure circumstances as Flood, Fire, EarthQuake and other acts of God as well as War, Military operation, blockade, Acts or Actions of State Authorities or any other circumstances beyond the parties control that have arisen after signing of the present contract. In such circumstances the time stipulated for the performance of an obligation under the present contract is extended correspondingly for the period of time of action of these circumstances and their consequences.

20. BID SPECIFIC TERMS & CONDITIONS FOR SUBMISSION OF TENDER FOR SUPPLY OF VARIOUS SIZE TOUCH & NON-TOUCH DISPLAY, VIDEO WALL, INFORMATION KIOSK ETC. FOR COAL GALLERY AT NATIONAL SCIENCE CENTRE, DELHI

1. Certificate of Incorporation.
2. Tender specific MAF from OEM of display.
3. OEM of display must have experience of similar assignments in Government organization/ Educational Institution.
4. OEM of display must have ISO Certificates of 9001, ISO 14001 & ISO45001 for manufacturing facility of product.
5. OEM of display must have minimum Turnover Rs. 1000 Crores average in the last three successive audited Financial Year in India: Balance Sheet & P & LA/c of last 3 yrs.
6. Undertaking from OEM of display of not being involved in any Bankruptcy filing or for protection from it.
7. Required minimum 5 number of Service Centre's present in state of Delhi: Proof of service centre Agreement /Office. Registration of OEM of display in Last 3 years.
8. 24 x 7 Toll free numbers for service support by OEM of display- Minimum two language supports (a. English b. Hindi): Toll free Number to confirm same available on website.
9. Online portal and email facilities for lodging & tracking of complaints of OEM of display.
10. Escalation matrix and contact details for the higher-level authorities for OEM of display support.
11. Product quoted must be manufactured in an OEM of display owned facility: Proof of factory & Test certificates for quoted product.
12. OEM's of display should have R&D facilities in India.
13. OEM of display undertaking as per guidelines published by Ministry of Finance, Dept. of Expenditure, Public Procurement Division

NATIONAL SCIENCE CENTRE
(A Unit of National Council of Science Museums)
Bhairon Road, Near Gate No. 4, Pragati Maidan,
New Delhi-110001

TENDER No. : NSCD/18011/E-Tender - 16/ 2023 - 24

DECLARATION-I

We do hereby accept the “General Terms & Conditions” as provided by the National Science Centre along with the Tender documents for “**Supply of various sizes touch & non-touch display, video wall, information kiosk etc. For Coal Gallery at National Science Centre, Delhi**” and also undertake to supply the said materials at National Science Centre, Delhi strictly as per the technical specifications of National Science Centre as provided along with the tender documents, in the event of placement of any order on us. The Centre shall be at liberty to cancel the order in full or in part in the event of failure of any of the above declarations made by us.

Signature of the Bidder / Constituted Attorney

DECLARATION-II

This is to certify that I/We have no close relative as an employee of the National Council of Science Museums (close relatives means: Father, Mother, Brother, Sister, Son, Daughter and Spouse) nor any such close relatives are associated with us as proprietor/partner/shareholder/ director and like.

Signature of the tenderer

Address:

Official seal with date

Bid Security (Earnest Money Deposit) Declaration in respect of MSMEs

(Format for Certificate /Declaration to be typed on the letter head of the bidder with rubber seal and to be submitted in Part -I
(TECHNICAL ENVELOPE) of the e-tender document)

We hereby declare that we (name of the bidder) are registered under Micro and Small & Medium Enterprises (MSME) and eligible for exemption for submitting Bid Security (EMD) for participating in the e-tender for Supply of various sizes touch & non-touch display, video wall, information kiosk etc. for Coal Gallery at National Science Centre, Delhi.

We further declare and accept that if we withdraw or modify our bid during the period of validity, or if we are awarded the contract and we fail to sign the contract, or to submit a Performance Security (Security Deposit) before the deadline defined in the e-NIT, we will be suspended for the period of time specified in the e-NIT from being eligible to submit bids for contract in Museum/Centre.

(Signature of the tenderer)
with seal/rubber stamp

Date:

**NATIONAL SCIENCE CENTRE
(A Unit of National Council of Science Museums)
Bhairon Road, Near Gate No. 4, Pragati Maidan,
New Delhi-110001**

TENDER No. : NSCD/18011/E-Tender - 16 / 2023 - 24

TECHNICAL (Techno-Commercial) BID

Notes: ALL PARTICULARS / INFORMATIONS SHOULD BE GIVEN IN THE FOLLOWING FORMAT WITH COMPLETE DETAILS.

01. Name & Address of the Firm/Bidder :
02. Telephone Number :
Office :
Office at Delhi/NCR :
03. i) Background details of the firm :
(State whether original manufacturer/direct Dealer of the manufacturer).

ii) In case of direct dealers, submit copy of valid dealership license issued by the manufacturer.
04. State the Name of the Banker including IFSC Code :
and Account Number of the Tenderer for releasing digital mode of payment.
05. Past experience in such business for last 3 years :
giving details of established clients especially Government Offices. Submit satisfactory certificate issued by such clients and Government Offices.
06. i) Whether capable to execute the tendered item strictly as per enclosed technical specification. (Please mention 'YES' or 'NO'

ii) If it is mentioned 'NO' above, submit detailed deviation to be made from the enclosed technical specification.
(Extra sheet may be attached, if required) :

iii) If it is mentioned 'YES' above submit copies of product brochure (for product categories) as a proof of their statement. :

07. State the Name & Address of the Manufacturer :
whose product has been offered /quoted by the tenderer.
08. Proof of financial status of the company/audited Balance :
Sheet for last 3 years indicating total turnover as well
(Submit documentary evidence.)
09. Whether agreed to accept 30 days credit Payment Terms. :
(Please mention 'Yes' or 'NO')
10. Minimum time required to complete the tendered item at :
NSC, Delhi.
11. Mention GST Registration Number and attach :
Current valid Tax Clearance Certificate.
12. Whether agreed to supply tendered items as per enclosed :
Specification (Annexure-E1 to E3) positively by 30 days and failing
which ready to absorb heavy penalty, if any order is placed on
the bidder after observing tender procedure.
(Please mention 'YES' or 'NO')

I/We hereby declare that the above statements are true. I/We also declare that the decision of National Science Centre, Delhi regarding selection of eligible firms for opening of Financial Bid (Part-II) shall be final and binding on me/us.

Dated

Official Seal

Signature of the Tenderer/Constituted Attorney

SPECIFICATIONS OF COMPUTER SYSTEM WITH MONITOR

ANNEXURE-E1

ITEM : 32" Inch Touch Display
Quantity: : 3 Nos.

| Item | Description | Compliance (Yes/No) | Remarks |
|-----------------------|---|---------------------|---------|
| Diagonal Size | 32" Touch Display | | |
| Resolution | 1920x1080(16:9) | | |
| Brightness (Typ.) | 400 nit (without Touch Glass) | | |
| Orientation | Landscape / Portrait | | |
| Haze | 2% (without glass) | | |
| Contrast Ratio (Typ.) | 5000:1 | | |
| Type | VA | | |
| Active Display area | 698.4(H) X 392.85(V) | | |
| Pixel Pitch(mm) | 0.3638 x 0.3638 | | |
| Color Gamut | 72% | | |
| Operation Hour | 16/7 | | |
| INPUT | HDMI 2.0(2) ,HDCP 2.2 , USB 2.0(2) | | |
| OUTPUT | Stereo mini Jack , Touch out 2(PC/screen) | | |
| EXTERNAL CONTROL | RS232C (in/out), RJ45 | | |
| Speaker | 10W 2ch | | |
| VESA Mount | 200 x 200 | | |
| Bezel Width (mm) | 24.5/24.5/21.5/21.5(U/D/L/R) | | |
| Key | FHD Signage Display with Built-in MagicInfo S6,SSSP 6.0 or Equivalent, Capacitive touch | | |
| Operating System | Tizen 4.0 (VDLinux) or equivalent | | |
| Processor | Cortex A72 1.7GHz Quad-Core CPU or equivalent | | |
| Storage FDM | 8GB | | |
| Safety | 60950-1 | | |
| EMC | Class B | | |
| Environment | ENERGY STAR 8.0, EPEAT | | |
| IP Rating | IP5x | | |
| Security | 802.1x(WPA2 Enterprise) :EAP-TLS, EAP-TTLS, EAP-PEAP | | |
| Power Supply | AC100 - 240 V, 50/60 Hz | | |
| Temperature | 0°C ~ 40°C | | |
| Relative Humidity | 10 ~ 80% | | |

Important Note :

1. It is the minimum required specifications. Vendors may offer product with higher or similar specifications that include MII product also.
2. Equipment must carry 03 years onsite ALL INDIA WARRANTY.
3. **VENDORS MUST SPECIFY THE MAKE AND MODEL OF THE OFFERED PRODUCT.**
4. **VENDORS MUST FILL-UP THE COMPLIANCE SHEET IN THE PRESCRIBED FORMAT ONLY GIVEN WITH THE SPECIFICATION SHEET.**
5. The display should have a minimum 10 point finger touch.

ITEM : 32" Inch Touch Kiosk with Computer System
Quantity : 15 Nos.

| Item | Description | Compliance (Yes/No) | Remarks |
|--------------------------------------|--|---------------------|---------|
| Diagonal Size | 32" Touch Display | | |
| Resolution | 1920x1080(16:9) | | |
| Brightness (Typ.) | 400nit (without Touch Glass) | | |
| Orientation | Landscape / Portrait | | |
| Haze | 2% (without glass) | | |
| Contrast Ratio (Typ.) | 5000:1 | | |
| Type | VA | | |
| Active Display area | 698.4(H) X 392.85(V) | | |
| Pixel Pitch(mm) | 0.3638 x 0.3638 | | |
| Color Gamut | 72% | | |
| Operation Hour | 16/7 | | |
| INPUT | HDMI 2.0(2) ,HDCP 2.2 , USB 2.0(2) | | |
| OUTPUT | Stereo mini Jack , Touch out 2(PC/screen) | | |
| EXTERNAL CONTROL | RS232C (in/out), RJ45 | | |
| Speaker | 10W 2ch | | |
| VESA Mount | 200 x 200 | | |
| Bezel Width (mm) | 24.5/24.5/21.5/21.5(U/D/L/R) | | |
| Key | FHD Signage Display with Built-in Magic Info S6 SSSP 6.0 or Equivalent, Capacitive touch | | |
| Operating System | Tizen 4.0 (VDLinux) or Equivalent | | |
| Processor | Cortex A72 1.7GHz Quad-Core CPU or Equivalent | | |
| Storage FDM | 8GB | | |
| Safety | 60950-1 | | |
| EMC | Class B | | |
| Environment | ENERGY STAR 8.0, EPEAT | | |
| IP Rating | IP5x | | |
| Security | 802.1x(WPA2 Enterprise) :EAP-TLS, EAP-TTLS, EAP-PEAP | | |
| Power Supply | AC100 - 240 V, 50/60 Hz | | |
| Temperature | 0°C ~ 40°C | | |
| Relative Humidity | 10 ~ 80% | | |
| Computer System Specification | | | |
| Make & Model | Intel , H.P. , Lenovo , Dell , or Equivalent Approved | | |
| Warranty | 3 years OEM Onsite Warranty | | |
| Processor | 10" / "11 Generation Intel Core I3 Processor | | |
| Operating System | Genuine Windows® 10/11 64 Bit English (pro) | | |
| RAM | 4GB DDR4 or more | | |
| Hard Drive | 256 GB SSD | | |
| Sound Card | Integrated HD Audio(Internal/External) | | |
| Graphic Card | Integrated H.D | | |
| Communications | Wireless (802,11a/g/n) WLAN & Bluetooth | | |

| | | | |
|--|---|--|--|
| I/O Ports | | | |
| Expansion Slots | Pcle 3.0x 16/ Pcle 3.0x1 (Internal/External) | | |
| Keyboard & Mouse | Wired Keyboard & Mouse | | |
| Energy Star | Energy Star Qualified | | |
| Speaker | 2.1 Multimedia Speaker (Creative , iBall or equivalent) | | |
| Metallic Kiosk Cabinet Specifications | | | |
| Thickness | 1.6mm metal (stainless steel) powdered coated (attach available shade card) | | |
| Mount | Floor mount kiosk cabinet with screw less chassis | | |
| Cabinet Cooling | Cooling fans installed inside kiosk | | |
| Power Extension | 4 point spike protector | | |
| Door Locks | Yes | | |
| Ease of Access | External USB, LAN and Power ON/OFF Ports | | |
| Logo & Color | Customized Logo and Color (will be shared later by the client). There is LED cove light in the lower part of KIOSK cabinet, Color will be shared later by the client | | |

Important Note:

1. It is the minimum required specifications. Vendors may offer higher or similar specifications that include MII product also.
2. Equipment must carry 3 years onsite ALL INDIA WARRANTY.
3. **VENDORS MUST SPECIFY THE MAKE AND MODEL OF THE OFFERED PRODUCT.**
4. **VENDORS MUST FILL-UP THE COMPLIANCE SHEET IN THE PRESCRIBED FORMAT ONLY GIVEN WITH THE SPECIFICATION SHEET.**
5. The display should have a minimum 10 point finger touch.
6. Agency can offer all in one based touch screen computer solution that should comply above minimum specification



ITEM : 43" Inch Non-Touch Display
 Quantity : 4 Nos.

| S. NO | Parameter | Specifications | Compliance (Yes/No) | Remarks |
|-------|-----------------------------|--|---------------------|---------|
| 1 | Diagonal Size | 43" | | |
| 2 | Resolution | 3840 x 2160 | | |
| 3 | Brightness(Typ.) | Minimum 350 cd/m2 | | |
| 4 | Native Contrast Ratio(Typ.) | 4000:1 or Higher | | |
| 5 | Viewing Angle(H/V) | 178 x 178 | | |
| 6 | Response Time | 8ms or lower | | |
| 7 | Operation Hour | 16x7 | | |
| 8 | Operating Life | 50000 hrs MTBF | | |
| 9 | Speaker Type | Built in Speaker (10W x 2) | | |
| 10 | Ports | HDMI -3, USB-2, RS232C(in/out), RJ45,WiFi | | |
| 11 | Direct/ Ease of Viewing | Display must have Direct Viewing of PPT, word, pdf, images & Videos from pen drive | | |
| 12 | IP Rating | IP5x | | |
| 13 | Power Consumption | 82 | | |
| 14 | Operating Temperature | 0°C ~ 40°C | | |
| 15 | Humidity | 10 ~ 80% | | |
| 16 | Processor | Cortex A72 1.7GHz Quad-Core CPU, 8 GB Inbuilt memory, | | |
| 17 | Orientation | Portrait and Landscape | | |
| 18 | Additional Parameters | Bid specific OEM MAF | | |
| | | 1. OEM should have a Service Center in Delhi/NCR for 3 years. Document required legal service agreement. | | |
| | | 2. Quoted model should be available on OEMs official website(also datasheet to be attached) | | |
| | | 3. OEMs should have a centralized call center for service call logging. | | |
| | | 4 CE,FCC,UL,BIS, ISO45001 | | |

Important Note :

1. It is the minimum required specifications. Vendors may offer higher or similar specifications that include **MII product also.**
2. Equipment must carry 3 years onsite ALL INDIA WARRANTY.
3. **VENDOR MUST SPECIFY THE MAKE AND MODEL OF THE OFFERED PRODUCT.**
4. **VENDOR MUST FILL-UP THE COMPLIANCE SHEET IN THE PRESCRIBED FORMAT ONLY GIVEN WITH THE SPECIFICATION SHEET.**

ITEM : 43" Touch Display
Quantity : 1 No.

| Item | Description | Compliance (Yes/No) | Remarks |
|-----------------------|--|---------------------|---------|
| Diagonal Size | 43" touch display | | |
| Resolution | 3840x2160(16:9) | | |
| Brightness (Typ.) | 500nit (without Glass) | | |
| Orientation | Landscape / Portrait | | |
| Haze | 25% (without glass) | | |
| Contrast Ratio (Typ.) | 4000:1(* IPS - 1200:1) | | |
| Type | VA | | |
| Active Display area | 941.184 (H) x 529.416 (V) | | |
| Pixel Pitch(mm) | 0.2451 x 0.2451 | | |
| Color Gamut | 92% (DCI-P3, CIE1976) | | |
| Operation Hour | 24/7 | | |
| INPUT | DP1.2(1), HDMI 2.0(3), HDCP 2.2, USB 2.0(2) | | |
| OUTPUT | Stereo mini Jack, Touch out 2(PC/screen) | | |
| EXTERNAL CONTROL | RS232C (in/out), RJ45 | | |
| Speaker | 10W 2ch | | |
| VESA Mount | 200 x 200 | | |
| Bezel Width (mm) | 26.0/26.0/21.0/21.0/(U/D/L/R) | | |
| Key | UHD Signage with Built-in- MagicInfo S10 SSSP 10.0 or equivalent | | |
| Operating System | Tizen 6.5 or equivalent | | |
| Processor | Cortex A72 1.7GHz Quad-Core CPU or equivalent | | |
| Storage FDM | 16GB | | |
| Safety | 60950-1 / 62368-1 | | |
| EMC | Class B | | |
| Environment | ENERGY STAR 8.0, EPEAT | | |
| IP Rating | IP5x | | |
| Security | 802.1x (WPA2 Enterprise :EAP-TLS, EAP-TTLS, EAP-PEAP | | |
| Power Supply | AC100 - 240 V, 50/60 Hz | | |
| Temperature | 0°C ~ 40°C | | |
| Relative Humidity | 10 ~ 80% | | |

Important Note:

1. It is the minimum required specifications. Vendors may offer higher or similar specifications that include MII product also.
2. Equipment must carry 3 years onsite ALL INDIA WARRANTY.
3. **VENDORS MUST SPECIFY THE MAKE AND MODEL OF THE OFFERED PRODUCT.**
4. **VENDORS MUST FILL-UP THE COMPLIANCE SHEET IN THE PRESCRIBED FORMAT ONLY GIVEN WITH THE SPECIFICATION SHEET.**

ITEM : 55" Inch Non-Touch Display
 Quantity : 4 Nos.

| S. NO | Parameter | Specifications | Compliance (Yes/No) | Remarks |
|-------|-----------------------------|--|---------------------|---------|
| 1 | Diagonal Size | 55" | | |
| 2 | Resolution | 3840 x 2160 | | |
| 3 | Brightness(Typ.) | Minimum 350 cd/m2 | | |
| 4 | Native Contrast Ratio(Typ.) | 4000:1 or Higher | | |
| 5 | Viewing Angle(H/V) | 178 x 178 | | |
| 6 | Response Time | 8ms or lower | | |
| 7 | Operation Hour | 16x7 | | |
| 8 | Operating Life | 50000 hrs MTBF | | |
| 9 | Speaker Type | Built in Speaker (10W x 2) | | |
| 10 | Ports | HDMI -3, USB-2, RS232C(in/out), RJ45,WiFi | | |
| 11 | Direct/ Ease of Viewing | Display must have Direct Viewing of PPT, word, pdf, images & Videos from pen drive | | |
| 12 | IP Rating | IP5x | | |
| 13 | Power Consumption | 96 | | |
| 14 | Operating Temperature | 0°C~ 40°C | | |
| 15 | Humidity | 10~80% | | |
| 16 | Processor | Cortex A72 1.7GHz Quad-Core CPU or equivalent, 8 GB Inbuilt memory, | | |
| 17 | Orientation | Portrait and Landscape | | |
| 18 | Additional Parameters | Bid specific OEM MAF | | |
| | | 1. OEM should have a Service Center in Delhi/NCR for 3 years. Document required - legal service agreement. | | |
| | | 2. Quoted model should be available on OEMs official website(also datasheet to be attached) | | |
| | | 3.OEMs should have a centralized call center for service call logging. | | |
| | | 4. CE,FCC,UL,BIS, ISO45001 | | |

Imp. Note :

- It is the minimum required specifications. **Vendors may offer higher or similar specifications that include MII product also.**
- Equipment must carry ALL INDIA WARRANTY.
- **VENDORS MUST SPECIFY THE MAKE AND MODEL OF THE OFFERED PRODUCT.**
- **VENDORS MUST FILL-UP THE COMPLIANCE SHEET IN THE PRESCRIBED FORMAT ONLY GIVEN WITH THE SPECIFICATION SHEET**

ITEM : **55" Inch TOUCH DISPLAY**
Quantity : **2 Nos.**

| Item | Description | Compliance (Yes/No) | Remarks |
|-----------------------|---|---------------------|---------|
| Diagonal Size | 55" touch display | | |
| Resolution | 3840x2160(16:9) | | |
| Brightness (Typ.) | 500 nit (Without Touch Glass) | | |
| Orientation | Landscape / Portrait | | |
| Haze | 25% (without glass) | | |
| Contrast Ratio (Typ.) | 4000:1 | | |
| Type | VA | | |
| Active Display area | 1209.6(H) x 680.4(V) | | |
| Pixel Pitch(mm) | 0.315 x 0.315 | | |
| Color Gamut | 92% (DCI-P3, CIE1976) | | |
| Operation Hour | 24/7 | | |
| INPUT | DP1.2(1), HDMI 2.0(3), HDCP 2.2, USB 2.0(2) | | |
| OUTPUT | Stereo mini Jack, Touch out 2(PC/screen) | | |
| EXTERNAL CONTROL | RS232C (in/out), RJ45 | | |
| Speaker | 10W 2ch | | |
| VESA Mount | 200 x 200 | | |
| Bezel Width (mm) | 26.0/26.0/21.0/21.0/(U/D/L/R) | | |
| Key | UHD Signage with Built-in- MagniInfo S10, SSSP 10.0 or equivalent | | |
| Operating System | Tizen 6.5 or equivalent | | |
| Processor | Cortex A72 1.7GHz Quad-Core CPU or equivalent | | |
| Storage FDM | 16GB | | |
| Safety | 60950-1 / 62368-1 | | |
| EMC | Class B | | |
| Environment | ENERGY STAR 8.0, EPEAT | | |
| IP Rating | IP5x | | |
| Security | 802.1x (WPA2 Enterprise :EAP-TLS, EAP-TTLS, EAP-PEAP | | |
| Power Supply | AC100 - 240V, 50/60 Hz | | |
| Temperature | 0°C ~ 40°C | | |
| Relative Humidity | 10 ~ 80% | | |

Important Note:

1. It is the minimum required specifications. **Vendors may offer higher or similar specifications that include MII product also.**
2. Vendors must fill-up the compliance sheet in the prescribed format only given with the specification sheet.
3. Equipment must carry 3 years onsite ALL INDIA WARRANTY.
4. **VENDOR MUST SPECIFY THE MAKE AND MODEL OF THE OFFERED PRODUCT**
5. **VENDORS MUST FILL-UP THE COMPLIANCE SHEET IN THE PRESCRIBED FORMAT ONLY GIVEN WITH THE SPECIFICATION SHEET.**
6. The display should have minimum 10 point finger touch

ITEM : 65" Inch Non-TOUCH DISPLAY

Quantity : 5 Nos.

| S. NO | Parameter | Specifications | Compliance (Yes/No) | Remarks |
|-------|-----------------------------|---|---------------------|---------|
| 1 | Diagonal Size | 65" | | |
| 2 | Resolution | 3840 x 2160 | | |
| 3 | Brightness(Typ.) | Minimum 350 cd/m2 | | |
| 4 | Native Contrast Ratio(Typ.) | 4000:1 or Higher | | |
| 5 | Viewing Angle(H/V) | 178 x 178 | | |
| 6 | Response Time | 8ms or lower | | |
| 7 | Operation Hour | 16x7 | | |
| 8 | Operating Life | 50000 hrs MTBF | | |
| 9 | Speaker Type | Built in Speaker (10W x 2) | | |
| 10 | Ports | HDMI -3, USB-2, RS232C(in/out), RJ45,WiFi | | |
| 11 | Direct/ Ease of Viewing | Display must have Direct Viewing of PPT, word, pdf, images & Videos from pen drive | | |
| 12 | IP Rating | IP5x | | |
| 13 | Power Consumption | 128W | | |
| 14 | Operating Temperature | 0°C ~ 40°C | | |
| 15 | Humidity | 10 ~ 80% | | |
| 16 | Processor | Cortex A72 1.7GHz Quad-Core CPU or equivalent, 8 GB Inbuilt memory, | | |
| 17 | Orientation | Portrait and Landscape | | |
| 18 | Additional Parameters | Bid specific OEM MAF | | |
| | | 1. OEM should have a Service Center in Delhi/NCR for 3 years. Document required -legal service agreement. | | |
| | | 2.Quoted model should be available on OEMs official website(also datasheet to be attached) | | |
| | | 3. OEM should have a centralized call center for service call logging. | | |
| | | 4. .CE,FCC,UL,BIS, ISO45001 | | |

Important Note for all annexures

1. It is the minimum required specifications. **Vendors may offer higher or similar specifications that include MII product also.**
2. Equipment must carry 3 years onsite ALL INDIA WARRANTY.
3. **VENDORS MUST SPECIFY THE MAKE AND MODEL OF THE OFFERED PRODUCT.**
4. **VENDORS MUST FILL-UP THE COMPLIANCE SHEET IN THE PRESCRIBED FORMAT ONLY GIVEN WITH THE SPECIFICATION SHEET.**

ITEM : 85" Inch Non-TOUCH DISPLAY

Quantity : 1 No.

| S. NO | Parameter | Specifications | Compliance (Yes/No) | Remarks |
|-------|-----------------------------|--|---------------------|---------|
| 1 | Diagonal Size | 85" | | |
| 2 | Resolution | 3840 x 2160 | | |
| 3 | Brightness(Typ.) | Minimum 350 cd/m2 | | |
| 4 | Native Contrast Ratio(Typ.) | 4000:1 or Higher | | |
| 5 | Viewing Angle(H/V) | 178 x 178 | | |
| 6 | Response Time | 8ms or lower | | |
| 7 | Operation Hour | 16x7 | | |
| 8 | Operating Life | 50000 hrs MTBF | | |
| 9 | Speaker Type | Built in Speaker (10W x 2) | | |
| 10 | Ports | HDMI -3, USB-2, RS232C(in/out), RJ45,WiFi | | |
| 11 | Direct/ Ease of Viewing | Display must have Direct Viewing of PPT, word, pdf, images & Videos from pen drive | | |
| 12 | IP Rating | IP5x | | |
| 13 | Power Consumption | 174(Typical) or less | | |
| 14 | Operating Temperature | 0°C ~ 40°C | | |
| 15 | Humidity | 10 ~ 80% | | |
| 16 | Processor | Cortex A72 1.7GHz Quad-Core CPU or equivalent, 8 GB Inbuilt memory, | | |
| 17 | Orientation | Portrait and Landscape | | |
| 18 | Additional Parameters | Bid specific OEM MAF | | |
| | | 1. OEM should have a Service Center in Delhi/NCR for 3 years. Document required - legal service agreement. | | |
| | | 2. OEM should not be Manufacturing quoted products from the countries sharing land border with India. | | |
| | | 3. Quoted model should be available on OEMs official website(also datasheet to be attached) | | |
| | | 4. OEM should have a centralized call center for service call logging. | | |
| | | 5. CE,FCC,UL,BIS, ISO45001 | | |
| 19 | Mechanical Mount | Require mounting of display in Portrait against the wall along with 8mm toughened glass protection | | |

Important Note for all annexures:

1. It is the minimum required specifications. **Vendors may offer higher or similar specifications that include MII product also.**
2. Equipment must carry 3 years onsite ALL INDIA WARRANTY.
3. **VENDORS MUST SPECIFY THE MAKE AND MODEL OF THE OFFERED PRODUCT.**
4. **VENDOR MUST FILL-UP THE COMPLIANCE SHEET IN THE PRESCRIBED FORMAT ONLY GIVEN WITH THE SPECIFICATION SHEET**

ITEM : **Transparent 55" Inch OLED**
Quantity : **2 Nos.**

| Item | Description | Compliance (YES / NO) | Remarks |
|--|--|-----------------------|---------|
| Screen Size | 55" | | |
| Panel Technology | OLED | | |
| Backlight Type | OLED | | |
| Aspect Ratio | 16:09 | | |
| Native Resolution | 1,920 x 1,080 (FHD) | | |
| Refresh Rate | 120 Hz | | |
| Brightness | 150/400nit (APL 100%/25%, Without Glass) | | |
| Contrast Ratio | 150,000 : 1 | | |
| Color Gamut | BT709 120% | | |
| Viewing Angle (H x V) | 178 × 178 | | |
| Color Depth | 10bit(R), 1.07Bilion colors | | |
| Response Time | 1ms (G to G), 8ms (MPRT) | | |
| Surface Treatment(Haze) | Haze 3% (SET), Hard coating (5H) | | |
| Shatter Proof | Yes | | |
| Lifetime (Typ.) | 30,000 Hrs | | |
| Operation Hours (Hours / Days) | 18 / 7 (Moving Content Only) | | |
| Portrait / Landscape | Yes / Yes | | |
| Transparency (Typ.) | 38% (SET) | | |
| Bezel Color | Transparent | | |
| Bezel Width | T/R/L/B : 7.9/7.9/7.9/168.6mm | | |
| Protection Glass (Depth) | 3.0 mm | | |
| Protection Glass (Tempered / Chemical Strengthening) | Chemical Strengthening | | |
| Protection Glass (Anti-Reflective) | Film | | |
| Protection Glass (Shatter-Proof) | Yes | | |
| Operation Temperature | 0 °C to 40 °C | | |
| Operation Humidity | 10 % to 80 % | | |
| Power Supply | AC 100-240V~, 50/60Hz | | |
| Power Type | Built-In Power | | |
| Typ./Max. | 250 W / 280 W | | |
| BTU (British Thermal Unit) | 853.03 BTU/Hr(Typ.), 955.39 BTU/Hr(Max.) | | |
| Safety | BIS, CB / NRTL | | |
| EMC | FCC Class "A" / CE / KC | | |
| ErP | Yes | | |
| SuperSign CMS | Yes | | |
| SuperSign Control / Control+ | Yes | | |
| SuperSign WB | Yes | | |
| Mobile CMS | Yes | | |

| | | | |
|------------------|--|--|--|
| ConnectedCare | Yes | | |
| Internal Memory | 16GB eMMC | | |
| Operating System | WebOS | | |
| Input | HDMI, DP, USB 2.0 Type A x 2 | | |
| Output | DP, Audio | | |
| External Control | RS232C In/Out, RJ45 (LAN) In/Out, IR In (External IR Receiver) | | |
| Inbuilt Sensor | Temperature Sensor | | |
| Basic | Remote Controller(include battery 2ea), Power Cord, QSG, Regulation Book, Phone to RS232C Gender, HDMI Cable(3M), Cable Holder 2EA | | |

Imp. Note :

- It is the minimum required specifications. Vendors may offer higher or similar specifications that include MII product also.
- Equipment must carry ALL INDIA WARRANTY.
- **VENDORS MUST SPECIFY THE MAKE AND MODEL OF THE OFFERED PRODUCT.**
- **VENDORS MUST FILL-UP THE COMPLIANCE SHEET IN THE PRESCRIBED FORMAT ONLY GIVEN WITH THE SPECIFICATION SHEET**

ITEM : 55" Inch Video Wall
Quantity : 12 Nos. of Displays.

| Item | Description | Compliance (YES / NO) | Remarks |
|--|--|-----------------------|---------|
| Diagonal Size | 55 inch | | |
| Resolution | 1920 x 1080 (Full HD) | | |
| Brightness(Typ.) | 500 nits or higher | | |
| Native Contrast Ratio(Typ.) | 1000:1 or higher | | |
| Viewing Angle(H/V) | 178:178 | | |
| Response Time | 8ms or lower | | |
| Operation Hour | 24/7 | | |
| Operating Life | 60000 hrs MTBF | | |
| Haze % for lesser reflection on screen | 25% or higher | | |
| Bezel Width | 1.74mm(Total effective bezel width) | | |
| Ports | DVI-D,DP, HDCP 2.2,HDMI 2.0(2), RS232C(in/out), RJ45 | | |
| IP Rating | IP5x | | |
| ADA Compliant and Depth of Video Wall | 80mm or less and should be ADA compliant | | |
| Certifications | CE,FCC,UL,BIS | | |
| Power Consumption | 135w(Typical) or less | | |
| Operating Temperature | 0°C ~ 40°C | | |
| Humidity | 10 ~ 80% | | |
| Features | ACM Support(Advanced Color Management) | | |
| Warranty | 3 years onsite from OEM | | |
| OEM MAF | Bid specific OEM MAF | | |
| Mechanical Mount | Require mounting of displays in matrix form of 3x2 for two walls having size of 8ft x 7ft (W x H) each along with 8mm toughened glass protection for each video wall | | |

Imp. Note :

- It is the minimum required specifications. Vendors may offer higher or similar specifications that include MII product also.
- Equipment must carry ALL INDIA WARRANTY.
- **VENDORS MUST SPECIFY THE MAKE AND MODEL OF THE OFFERED PRODUCT.**
- **VENDORS MUST FILL-UP THE COMPLIANCE SHEET IN THE PRESCRIBED FORMAT ONLY GIVEN WITH THE SPECIFICATION SHEET**
- The successful vendor has to install these video walls at site. Means procurement of this item is under SITC.

ITEM :32" Inch Touch Display with cabinet (there are two type of cabinet each required 2 no's)

Quantity:4 Nos.

| Item | Description | Compliance (Yes/No) | Remarks |
|-----------------------|---|---------------------|---------|
| Diagonal Size | 32" Touch Display | | |
| Resolution | 1920x1080(16:9) | | |
| Brightness (Typ.) | 400 nit (without Touch Glass) | | |
| Orientation | Landscape / Portrait | | |
| Haze | 2% (without glass) | | |
| Contrast Ratio (Typ.) | 5000:1 | | |
| Type | VA | | |
| Active Display area | 698.4(H) X 392.85(V) | | |
| Pixel Pitch(mm) | 0.3638 x 0.3638 | | |
| Color Gamut | 72% | | |
| Operation Hour | 16/7 | | |
| INPUT | HDMI 2.0(2) ,HDCP 2.2 , USB 2.0(2) | | |
| OUTPUT | Stereo mini Jack , Touch out 2(PC/screen) | | |
| EXTERNAL CONTROL | RS232C (in/out), RJ45 | | |
| Speaker | 10W 2ch | | |
| VESA Mount | 200 x 200 | | |
| Bezel Width (mm) | 24.5/24.5/21.5/21.5(U/D/L/R) | | |
| Key | FHD Signage Display with Built-in MagicInfo S6,SSSP 6.0, Cap touch or equivalent, Cap touch | | |
| Operating System | Tizen 4.0 (VDLinux) or equivalent | | |
| Processor | Cortex A72 1.7GHz Quad-Core CPU or equivalent | | |
| Storage FDM | 8GB | | |
| Safety | 60950-1 | | |
| EMC | Class B | | |
| Environment | ENERGY STAR 8.0, EPEAT | | |
| IP Rating | IP5x | | |
| Security | 802.1x(WPA2Enterprise) :EAP-TLS, EAP-TTLS, EAP-PEAP | | |
| Power Supply | AC100 - 240 V, 50/60 Hz | | |
| Temperature | 0°C ~ 40°C | | |
| Relative Humidity | 10 ~ 80% | | |

Important Note :

- It is the minimum required specifications. Vendors may offer higher or similar specifications that include MII product also.
- Equipment must carry 03 years onsite ALL INDIA WARRANTY.
- **VENDORS MUST SPECIFY THE MAKE AND MODEL OF THE OFFERED PRODUCT.**
- **VENDORS MUST FILL-UP THE COMPLIANCE SHEET IN THE PRESCRIBED FORMAT ONLY GIVEN WITH THE SPECIFICATION SHEET.**
- The display should have a minimum 10 point finger touch
- Cabinet specification, measurement, quantity and related drawings are provided in the next page.
- There are two type of cabinet with 32" display. Quantity required no 2 each.
- There is LED cove lighting for each cabinet.

- Any confusion during the construction of the cabinet must be resolved in consultation with the authorities of the National Science Centre, Delhi.

-

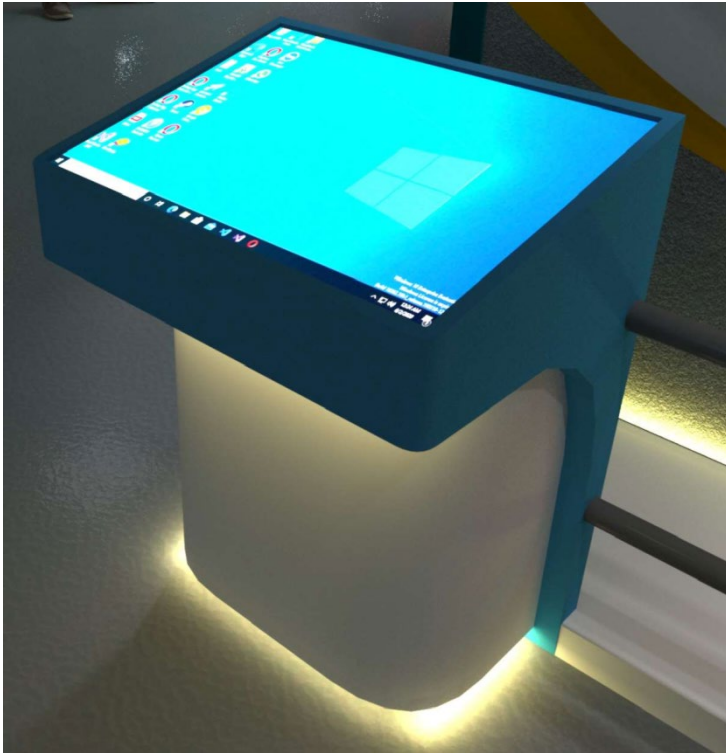

Qty : 02 No's

Blue blush

Please follow the laminate colour of
Blue Blush
3241- (Century laminates)

Off white

Please follow the laminate colour of
Off White - 108
(Century laminates)

Material-

Acrylic Solid Surface/ Corian

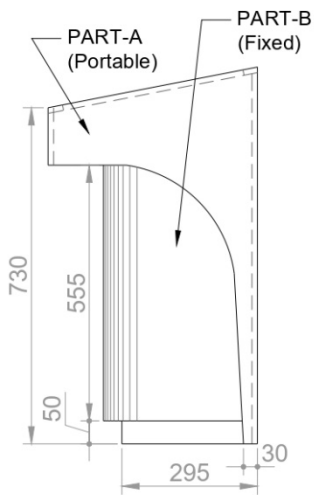

SIDE VIEW

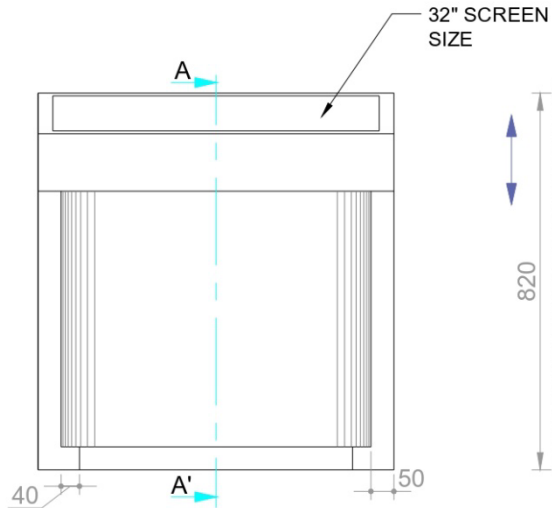

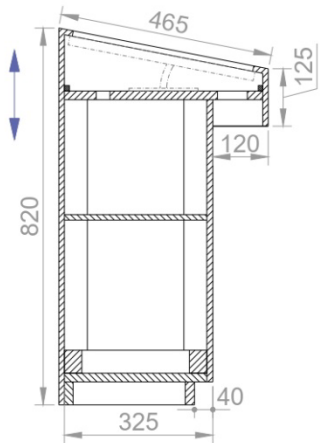

FRONT VIEW

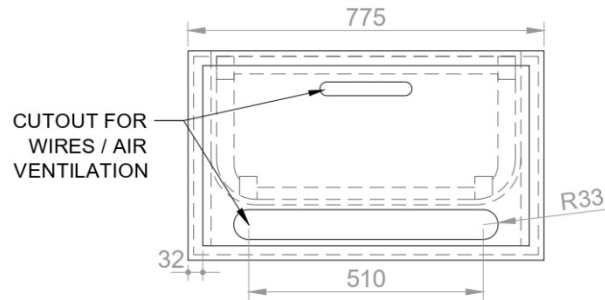

SECTION-AA'



TOP VIEW

| | | | |
|--|------------------------------------|-------------|----------------|
| NATIONAL SCIENCE CENTRE, DELHI  | | NAME | DATE |
| | | DRAWN BY | |
| | | CHECKED BY | |
| UNIT | ALL DIMENSIONS ARE IN MM. | APPROVED BY | |
| 1:1 | TITLE : | SHEET NO. | 01 |
|  | 9 PILLERS OF DIGITAL INDIA (KIOSK) | DRAWING NO. | NSCD/DIG/IS/04 |

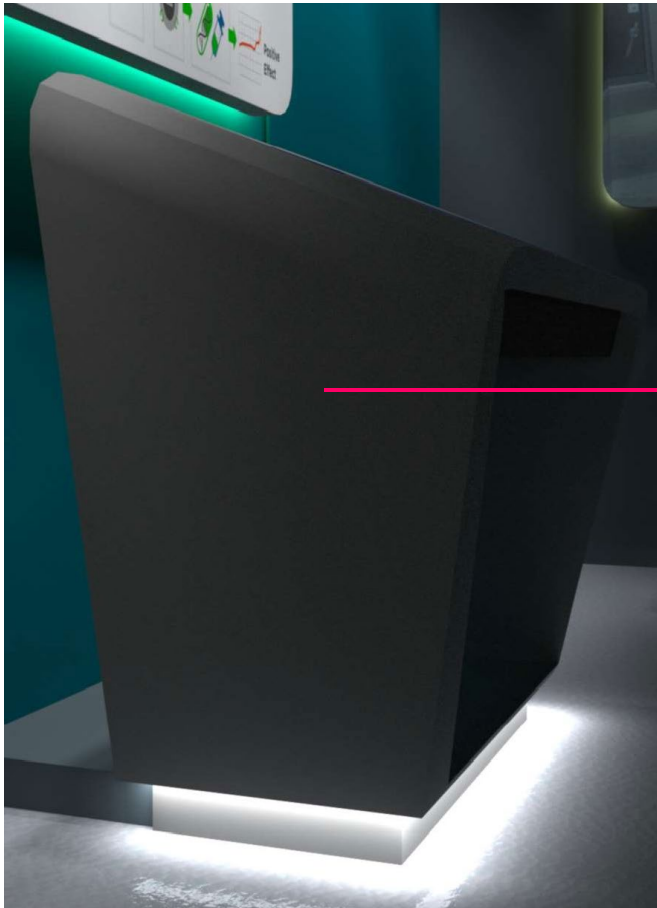

Qty : 02 No's

Off white

Please follow the laminate colour of
Graphite Gray - **238**
(Century laminates)

Material-

Acrylic Solid Surface/ Corian

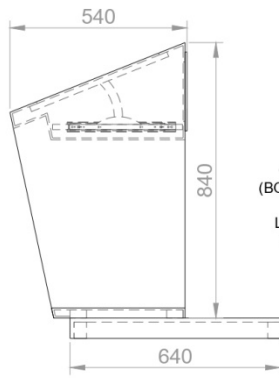

SIDE VIEW

6 MM PLY
(BOTH SIDE)
WITH
LAMINATE
FINISHED

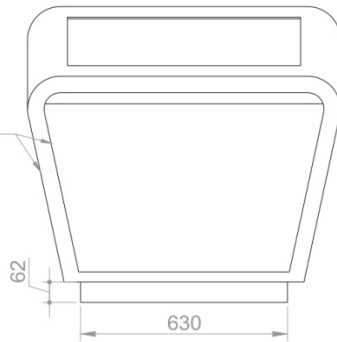

FRONT VIEW

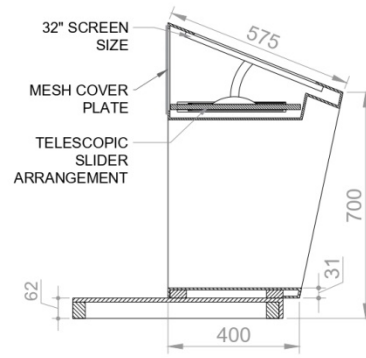

SECTION AA'

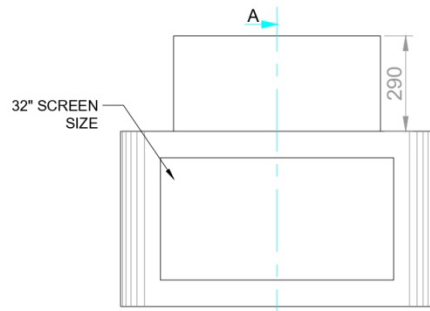

TOP VIEW

NOTES:-

1. For material specs and finishes, please refer to the specification sheet of tender document.
2. Dimensions given here are tentative and may vary as per site condition.
3. All exposed area to be covered with 1mm laminate sheet (of approved make and color)

| | | | | |
|--------------------------------|---------------------------|-------------|--|---------------|
| NATIONAL SCIENCE CENTRE, DELHI | | NAME | | DATE |
| | | DRAWN BY | | |
| | | CHECKED BY | | |
| | | APPROVED BY | | |
| UNIT | ALL DIMENSIONS ARE IN MM. | SHEET NO. | | 01 |
| 1:1 | TITLE : | DRAWING NO. | | NSCD.DIG.1505 |
| | M-RNA VACCINE GAME | | | |

BANK DETAILS OF NATIONAL SCIENCE CENTRE, DELHI

| | |
|----------------------------|--------------------------------|
| Name of the Account Holder | NATIONAL SCIENCE CENTRE, DELHI |
| Account No. | 2417101004100 |
| Bank Name | CANARA BANK |
| Bank Address | 6, Bhagwan Das Road, New Delhi |
| IFSC Code | CNRB0002417 |
| MICR Code | 110015045 |
| Type of Account | Saving Account |
| Branch Code | 2417 |
| GST No. | 07AAAAN2541C1Z5 |